



China Patent No.ZL201720650460.8

Multi-functional Flow Control Valve for Water Treatment Systems

82602 (Old Model: F79A-LCD)

82602B (Old Model: F79B-LCD)

82604 (Old Model: F82A-LCD)

82604B (Old Model: F82B-LCD)

82604AB (Old Model: F82AG-LCD)

82604BB (Old Model: F82BG-LCD)

User Manual



Please read this manual in details
before using this valve and keep it properly
in order to consult in the future.

0WRX.466.515

Before the valve put into use, please fill in the below content so as to help us to refer in the future.

The Program Type Setting (Operation by professional)

When all symbols light on, press and hold  and  buttons for 5 seconds to enter the menu of valve model selection.

Softener System Configuration

Tank Size: Dia. _____ mm, Height _____ mm;
 Resin Volume _____ L; Brine Tank Capacity _____ L;
 Hardness of Raw Water _____ mmol/L;
 Pressure of Inlet Water _____ MPa;
 Control Valve Model _____; Number _____;
 The Specification of Drain Line Flow Control _____;
 Injector No. _____.

Water Source: Ground-water ; Filtered Ground-water ;

Tap Water ; Other _____.

Parameter Set

Parameter	Unit	Factory Default	Actual Value
Control Mode A-01(02/03/11/12/13/21)	/	A-01	
Water Treatment Capacity(Meter type)	m ³	10.00	
Recharge Time	/	02:00	
Interval Backwash Times	/	F-00	
Repeat-Washing Times	/	02:00	
Rinsing Frequency	/	F-00	
Backwash Time	min.	10:00	
Brine & Slow Rinse Time	min.	60:00	
Brine Refill Time	min.	05:00	
Fast Rinse Time	min.	10:00	
Max Days Between Recharges	D	30	
Output Mode b-01(02)	/	b-01	

●If there is no special requirement when product purchase, we choose 3# drain line flow control, and 6305 injector for the F79 standard configuration. We choose 5# drain line flow control, and 6309 injector for the F82 standard configuration.

Catalogue

Notice	3
1.Product Overview	4
1.1.Main Application & Applicability	4
1.2.Product Characteristics	4
1.3.Service Condition	7
1.4.Product Structure and Technical Parameters	7
1.5.Installation	9
2.Basic Setting & Usage	12
2.1.The Function of PC Board	12
2.2.Basic Setting & Usage	13
3. Applications	17
3.1. Softener Flow Chart	17
3.2. The Function and Connection of PC Board	17
A. Signal Output Connector	18
B. Disinfection Device Connector	21
C. Salt Shortage Alarm Device	21
D. Remote Handling Connector	22
3.3. System Configuration and Flow Rate Curve	23
3.4. Parameter Settlement	26
3.5. Parameter Enquiry and Setting	28
3.6. Trial Running	31
3.7. Trouble-shooting	32
3.8 . Assembly & Parts	35
4. Warranty Card	44

Notice

- To ensure normal operation of the valve, please consult with professional installation or repairing personnel before use it.
- If there are any of pipeline engineering and electric works, they must be finished by professional at the time of installation.
- Do not use the control valve with the water that is unsafe or unknown quality.
- Depending on the changing of working environment and water requirement, each parameter of softener should be adjusted accordingly.
- When the water treatment capacity is too low, please check the resin. If the reason is short of resin, please add; if the resin is turn to reddish brown or broken, please replace.
- Test water periodically to verify that system is performing satisfactorily.
- Ensure that there is solid salt all the time in the brine tank in the course of using, when this valve is used for softening. The brine tank should be added the crystalline coarse salt only, at least 99.5% pure, forbidding use the small salt.
- Do not put the valve near heat sources or surroundings with high humidity, corrosive, intense magnetic field or intense vibrations environment. And do not leave it outside.
- Forbidden to carry the injector body. Avoid to use injector body as support to carry the system.
- Forbidden to use the brine tube or other connectors as support to carry the system.
- Please use this product under the water temperature between 5~50℃, water pressure 0.15~0.6MPa. Failure to use this product under such conditions voids the warranty.
- If the water pressure exceeds 0.6MPa, a pressure reducing valve must be installed before the water inlet. While, if the water pressure is under 0.15MPa, a booster pump must be installed before the water inlet.
- PPR pipes, corrugated pipes, or UPVC pipes are recommended for pipe installation and aluminum-plastic pipes should be avoided.
- Do not let children touch or play, because careless operations may cause the procedure changed.
- When the attached cables of this product and transformer are damaged, they must be changed to the one that is from our factory.

1. Product Overview

1.1. Main Application & Applicability

Used for softening or demineralization water treatment systems

Be suitable for

Residential softening system

Residential filtering system

1.2. Product Characteristics

● Simple structure and reliable sealing

It adopts hermetic head faces with high degree pottery and corrosion resistance for opening and closing. It combines with Service, Backwash, Brine & Slow Rinse, Brine Refill and Fast Rinse.

● Manual function

Realize regeneration immediately by pressing  at any time.

Set Time of Day

12:30

● Long outage indicator



If outage overrides 3 days, the time of day indicator  will flash to remind people to reset new time of day. (Refer to the figure)

Figure 1-A



● LCD Screen Display

Adopt wordage to display all status, which is clear and briefly.

Users can choose English or other language display interface in this way:

Connecting power then press buttons  and  for 5 seconds to enter language choice interface.

● Buttons lock

No operations to buttons on the controller within 1 minute, button lock indicator lights on which represent buttons are locked. Before operation, press and hold the  and  buttons for 5 seconds to unlock. This function can avoid incorrect operation.

● The F79 with weather cover can be installed outside.

● Has hard water bypass and no hard water bypass two choices

No hard water bypass refers to the control valve no water passes when valve in regeneration. Model: A for no hard water bypass (No raw water flows out from outlet when in regeneration process); B for with hard water bypass (With raw water flows out from outlet when in regeneration process).

● With partial bypass function

In service, by adjusting bypass screw can let part of raw water flow into the outlet without being softened.

● **Down-flow regeneration, up-flow regeneration and filter can be implemented with a valve.**

By program selection to choose following modes

Mode	Name	Instruction
A-01	Down-flow Regeneration, Meter Delayed	Down-flow regeneration, will not regenerate although the available volume of treated water drops to zero (0). Regeneration will start until at the regeneration time.
A-02	Down-flow Regeneration, Meter Immediate	Down-flow regeneration, regenerate immediately when the available volume of treated water drops to zero (0).
A-03	Down-flow Regeneration, Intelligent Meter Delayed	Down-flow regeneration, regeneration starts at the regeneration time of the current day when the available volume of treated water less than the average water consumption of last 7 days.
A-11	Up-flow Regeneration, Meter Delayed	Up-flow regeneration, will not regenerate although the available volume water of treated water drops to zero (0). Regeneration will start until at the regeneration time.
A-12	Up-flow Regeneration, Meter Immediate	Up-flow regeneration, regenerate when the available volume of treated water drops to zero (0).
A-13	Up-flow Regeneration, Intelligent Meter Delayed	Up-flow regeneration, regeneration starts at the regeneration time of the current day when the available volume of treated water less than the average water consumption of last 7 days.
A-21	Filter Type	Filter type, rinsing when the service days or available capacity reach to zero (0) and the current time is matched with rinsing time.

● **Interval backwash times (Only suitable for up-flow regeneration valve)**

It could set up interval backwash times for up-flow type A-11, 12, 13, which means several times of services but one time of backwash. The setting of interval backwash time depends on the local water turbidity. (The lower the turbidity is, the longer the interval backwash time can be set)

● **Rinsing frequency**

It could set up rinsing frequency when selection of filter mode A-21, which means several times of backwash and fast rinse but one time of service (Can be set). In this working mode, the brine line connector needs to be sucked and DLFC needs to be taken off.

● Signal output

There is a signal output connector on main control board. It is for controlling external wiring (Refer to Figure 3-1 to Figure 3-8).

There are two kinds of output modes. b-01 mode: Turn on start of regeneration and shut off end of regeneration; b-02 mode: Signal available only in intervals of regeneration cycles and in service.

b-01

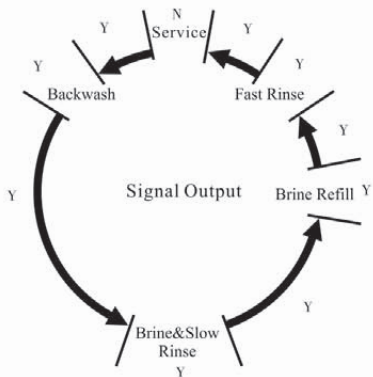

b-02

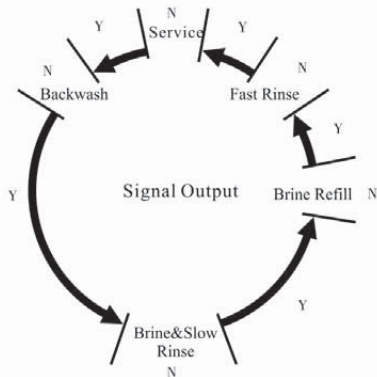

● Remote handling input

This connector can receive external signal, used together with PLC, and computer etc. to control the valve. (Application refers to Figure 3-11)

● Disinfection connector (It is necessary to separately match with a disinfection device that is additional device)

The valve has the disinfection connector, which can supply DC5V 200mA power output under the Brine Draw status. It can make a part of brine electrolyzed, and produce hypochlorous acid to sterilize and disinfect the resin. (Wiring refers to Figure on page 21)

● Connector of salt shortage alarm (It is necessary to separately match with a gravity meter.)

The connector is jointed with gravity meter. When the brine tank is short of salt, the system will give the alarm and remind user to add the salt in time. (Wiring refers Figure on page 21)

● Maximum interval regeneration days

Under the situation of service reaching the setting days but the volume not yet, it could enter into regeneration process forcibly when current time is the same as regeneration time.

● All parameters can be modified

According to the water quality and usage, the parameters in the process can be adjusted.

1.3. Service Condition

Runxin Valve should be used under the below conditions:

Items		Requirement
Working conditions	Water pressure	0.15MPa ~ 0.6MPa
	Water temperature	5°C ~ 50°C
Working environment	Environment temperature	5°C ~ 50°C
	Relative humidity	≤95% (25°C)
	Electrical facility	AC100 ~ 240V/50 ~ 60Hz
Inlet water quality	Water turbidity	Down-flow regeneration < 5FTU; Up-flow regeneration < 2FTU Filter < 20FTU
	Water hardness	First grade Na ⁺ < 6.5mmol/L; Second grade Na ⁺ < 10mmol/L
	Free chlorine	< 0.1mg/L
	Iron ²⁺	< 0.3mg/L
	CODMn	< 2 mg/L (O ₂)

● When the water turbidity exceeds the conditions, a filter should be installed on the inlet of control valve.

● The requirement for free chlorine is just suit for softener mode but not filter mode.

1.4. Product Structure and Technical Parameters

A. Product dimension (The appearance is just for reference. It is subjected to the real product.)
F79A-LCD/F79B-LCD (82602/82602B)

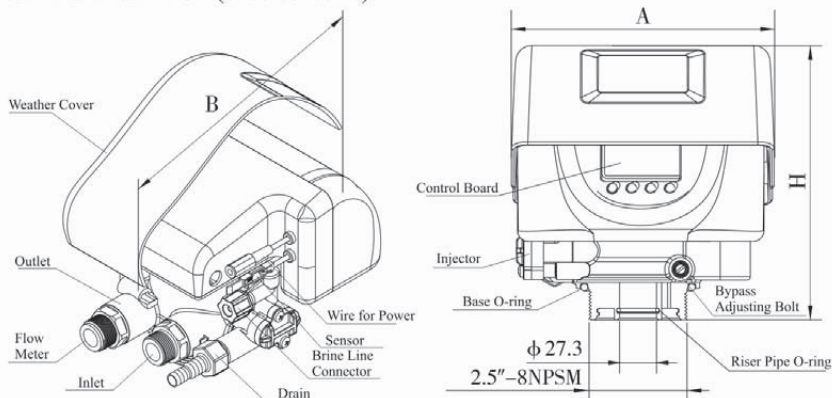

F82A-LCD(82604)/F82B-LCD(82604B)

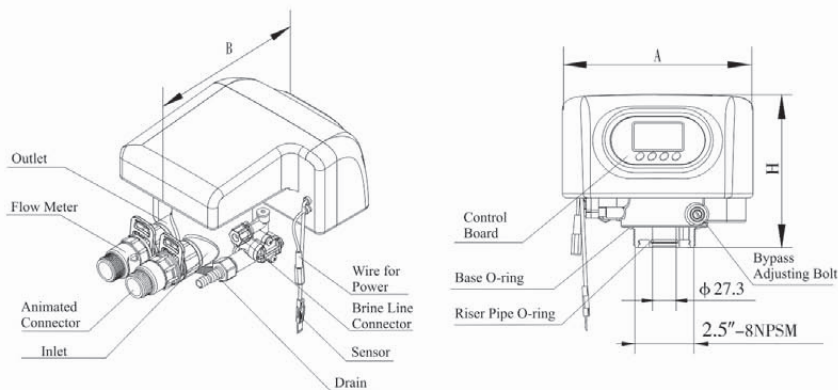

F82AG-LCD (82604AB)/F82BG-LCD (82604BB)

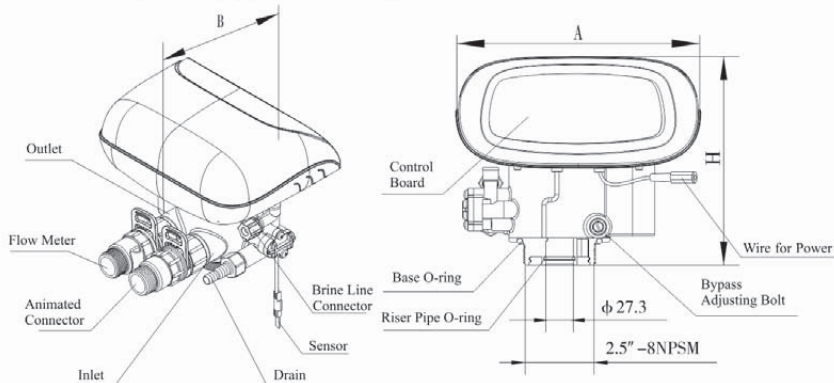

Model	A(mm)max	B(mm)max	H(mm)max
F79A/F79B-LCD	186	230	200
F82A/F82B-LCD	220	260	180
F82AG/F82BG-LCD	240	200	205

B. Technical parameter

Control valve are suitable for the power adapter output: DC12V, 1.5A.

Model	Connector Size					Water Capacity m ³ /h @0.3MPa	Remark
	Inlet/ Outlet	Drain	Brine Line Connector	Base	Riser Pipe		
F79A-LCD	3/4" M	1/2" M	3/8" M	2-1/2"- 8NPSM	1.05" OD (26.7mm)	2	No raw water passes valve when regeneration
F79B-LCD							With raw water passes valve when regeneration
F82A-LCD	1" M	1/2" M	3/8" M	2-1/2"- 8NPSM	1.05" OD (26.7mm)	3.5	No raw water passes valve when regeneration
F82B-LCD							With raw water passes valve when regeneration
F82AG-LCD	1" M	1/2" M	3/8" M	2-1/2"- 8NPSM	1.05" OD (26.7mm)	3.5	No raw water passes valve when regeneration
F82BG-LCD							With raw water passes valve when regeneration

Note: M-Male, F-Female, OD: Outer Diameter

1.5.Installation

A. Install notice

Before installation, read all those instructions completely. Then obtain all materials and tools needed for installation.

The installation of product, pipes and circuits, should be accomplished by professional to ensure the product can operate normally.

Perform installation according to the relevant pipeline regulations and the specification of Water Inlet, Water Outlet, Drain Outlet, and Brine Line Connector.

B. Device location

- ①The filter or softener should be located close to drain.
- ②Ensure the unit is installed in enough space for operating and maintenance.
- ③Brine tank needs to be close to softener.
- ④The unit should be kept away the heater, and not be exposed outdoor. Sunshine or rain will cause the system damage.
- ⑤Avoid installing the system in circumstance of acid/alkaline, magnetic or strong vibration, because above factors will cause the system disorder.
- ⑥Do not install the filter or softener, drain pipeline or overflow pipe in circumstance where temperature may drop below 5℃, or above 50℃.
- ⑦Install the system in the place where with the minimum loss in case of water leakage.

C. Pipeline installation (Take F82 as sample)

① Install control valve

a. As the Figure 1-1 shows, select the riser pipe with 26.7 mm OD, glue the riser pipe to the bottom strainer and put it into the bottom of tank, cut off the exceeding pipe out of tank top opening and make external rounding.

b. Fill the resin to the tank, and the height is accordance with the design code.

c. Install the top strainer to the valve.

d. Through the top strainer, insert the riser pipe into control valve and screw control valve on the resin tank tightly.

Note:

● The length of riser pipe should be neither 2mm higher nor 5mm lower than tank top opening, and its top end should be rounded to avoid damaging of O-ring inside the valve.

● Avoid filling floccules substance together with resin to the resin tank.

● Avoid O-ring inside control valve falling out while rotating it on the tank.

② Install animated connector

As Figure1-2 shows, put the sealing ring into nut of animated connector, and screw in water inlet.

③ Install flow meter

As Figure1-2 shows, put the sealing ring into nut of flow meter, screw in water outlet; insert the probe wire into flow meter.

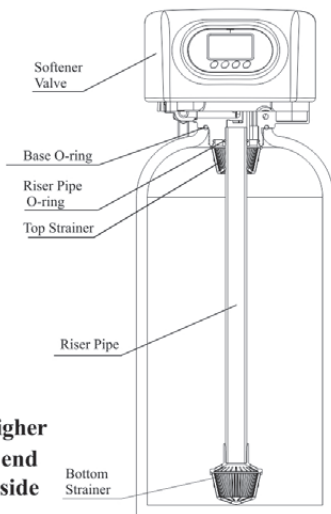

Figure 1-1

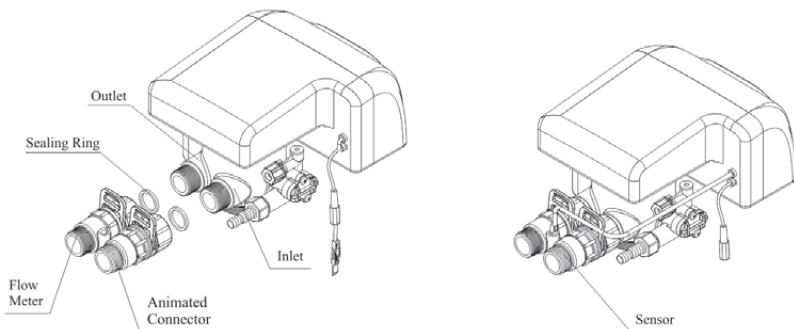

Figure 1-2

④ Pipeline connection

- As Figure 1-3 shows, install a pressure gauge in water inlet.
- Install valve A, valve B, valve C and valve D in the inlet, outlet and middle of the pipeline. The valve D is sampling valve. (Or adopt F70C/F70D bypass valve.)
- Inlet pipeline should be in parallel with outlet pipeline. Support inlet and outlet pipeline with fixed holder.

Note:

- If making a soldered copper installation, do all sweat soldering before connecting pipes to the valve. Torch heat will damage plastic parts.

- When turning threaded pipe fitting onto plastic fitting, do not use excessive force to make threads misaligned or broken valve.

- If the valve belongs to time clock type or F79, there are no step ② and ③.

⑤ Install drain pipeline

- As the Figure 1-4 shows, slide the drain hose connector into drain outlet.
- Insert drain line flow control into drain outlet.
- Screw drain hose connector into drain outlet, and lock it.
- Locate the drain hose as well as the Figure 1-4 shows.

Note:

- Control valve should be higher than drain outlet, and be better not far from the drain hose.

- Be sure not connect drain pipe with sewer directly, and leave a certain space between them, avoid wastewater being absorbed to the water treatment equipment, such as showed in the Figure 1-4. If want to use the wastewater for other use, it can be filled with a corresponding container. Similarly, the drain pipe should be kept a certain space with the container.

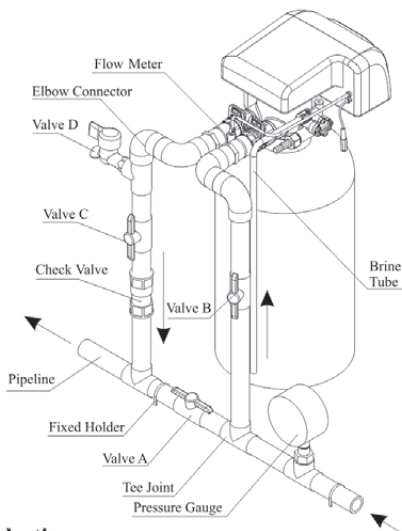

Figure 1-3

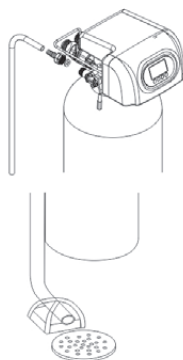

Figure 1-4

⑥ Connect brine tube

- As Figure 1-5 shows, slide 3/8" brine tube hose connector over end of brine tube.
- Insert tube bushing into the end of brine tube.
- Insert the red brine line flow control into valve brine line connector (Note: cone side of control should face into valve).
- Tighten nut onto brine line connector.
- Connect the other end of brine tube with the brine tank. (The liquid level controller and brine valve with air-blocker should be installed in the brine tank.)

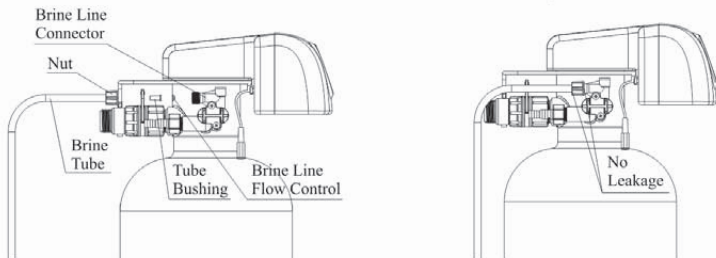
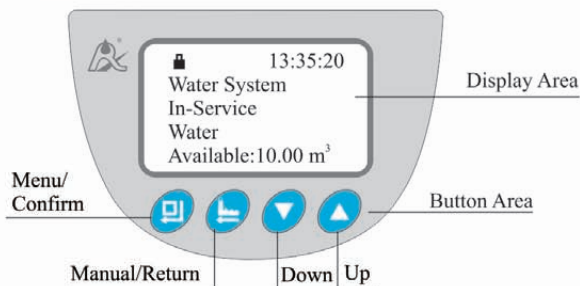

Figure 1-5

Note: The brine tube and drain pipeline should not be bended or plugged.

2. Basic Setting & Usage

2.1. The Function of PC Board





A. Button lock indicator

- lights on, indicates the buttons are locked. At this moment, press any single button will not work (No operation in one minute, will light on and lock the buttons.)
- Solution: Press and hold both and for 5 seconds until the lights off.



B. Menu/Confirm button



- In menu mode, press , then enter program display mode to view all values.

● In program display mode, press , data flashes, enter program set mode, choose and adjust parameter values.

● Press  after all parameters are set, and then the voice “Di” means all setting are successful and return program display mode.

C.  Manual/Return button



● Press  in any status, it can proceed to next step. (Example: After unlock the buttons, press  in service status, it will start regeneration cycles instantly if the outlet water is unqualified; Press  while it is in backwash status, it will end backwash and go to brine & slow rinse at once).

● Press  in program display mode, and it will return in service; Press  in program set mode, and it will return program display mode.

● Press  while adjusting the value, then it will return program display mode directly without saving value.

D. Up  and Down 

● In program display mode, press  or  to view all values.

● In program set mode, press  or  to adjust values.

● Press and hold both  and  for 5 seconds to unlock the buttons.

2.2. Basic Setting & Usage

A. Parameter specification

Function	Factory Default	Parameter Set Range	Instruction
Time of Day	Random	00:00~23:59	
Control Model	A-01	A-01	Down-flow regeneration, will not regenerate although the available volume of treated water drops to zero (0). Regeneration will start until at the regeneration time.
		A-02	Down-flow regeneration, regenerate immediately when the available volume of treated water drops to zero (0).
		A-03	Down-flow regeneration, regeneration starts at the regeneration time of the current day when the available volume of treated water less than the average water consumption of last 7 days.
		A-11	Up-flow regeneration, will not regenerate although the available volume water of treated water drops to zero (0). Regeneration will start until at the regeneration time.

Control Model	A-01	A-12	Up-flow regeneration, regenerate when the available volume of treated water drops to zero (0).
		A-13	Up-flow regeneration, regeneration starts at the regeneration time of the current day when the available volume of treated water less than the average water consumption of last 7 days.
		A-21	Filter type, rising when the service days or available capacity reach to zero (0) and the current time is matched with rinsing time.
Recharge Time	02:00	00:00~23:59	A-01/03/11/13/21
Interval Backwash Times	00	0~20	Interval backwash times. For example, F-01: indicates service 2 times, backwash 1 time (Only for A-11/12/13)
Repeat-Washing Times	00	0~20	Rinsing added times. For example, F-01: indicates rinse 2 times, service 1 time (Only for A-21)
Water Treatment Capacity	10m ³	0~99.99 m ³	Water treatment capacity in one circle (m ³) for: A-01/02/03/11/12/13
Backwash Time	10min.	0~99:59	Backwash time (minute)
Brine & Slow Rinse Time	60min.	0~99:59	Brine & slow rinse time (minute)
Brine Refill Time	5min.	0~99:59	Brine refill time (minute)
Fast Rinse Time	10min.	0~99:59	Fast rinse time(minute)
Max Days Between Recharges	30	0~40	Regenerate at the regeneration time even though the available volume of treated water does not drop to zero (0).
Output Control Mode	01	01 or 02	b-01: Signal turn on when start of regeneration and shut off at the end of regeneration. (Connection refers to the Figures on page 4) b-02: Signal available only in intervals of each status. (Connection refers to the Figures on page 4)

B. Process Display (Take A-03 working mode as example)

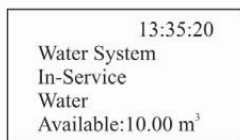

Figure A

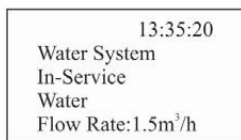

Figure B

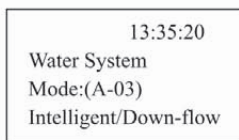

Figure C

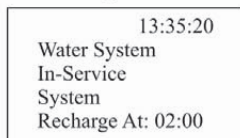

Figure D

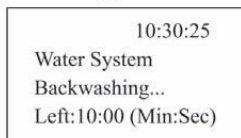

Figure E

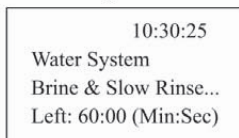

Figure F

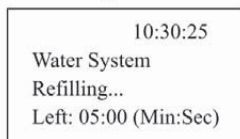

Figure G

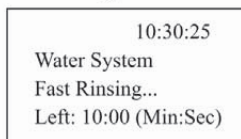

Figure H

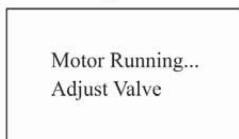

Figure J

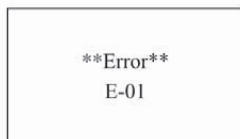

Figure I

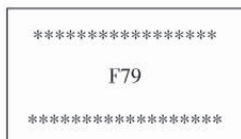

Figure L

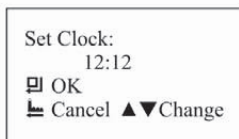



Figure M













Illustration:

- The display screen shows Figure M, indicates outage of power more than 3 days. It reminds to adjust the time of day.
- The display screen shows Figure L when connected with power. At the Service status shows circularly: Figure A/B/C/D.
- The display screen shows Figure E at Backwash status and shows Figure F at the Brine & Slow Rinse status.
- The display screen shows Figure G at Brine Refill status and shows Figure H at Fast Rinse status.
- When control valve turns from one working status to another, the screen shows Figure J.
- The display will show Figure I when the system is in error.
- Working process: Service → Backwash → Brine & Slow Rinse → Brine Refill → Fast Rinse.

C. Usage

After being accomplished installation, parameter setting and trail running by professional, the valve could be put into use. In order to ensure the quality of outlet water can reach the requirement, the user should complete the below works:

- ① Ensure that there is solid salt all the time in the brine tank in the course of using when this valve is used for softening. The brine tank should be added the crystalline coarse salt only, at least 99.5% pure, forbidding use the small salt and iodized salt.
- ② Test the hardness of outlet water and raw water at regular time. When the outlet water hardness is unqualified, please press the  and the valve will temporarily regenerate again (It will not affect the original set operation cycle.)
- ③ When the feed raw water hardness changes a lot, you can adjust the water treatment capacity as follow:

Press and hold both  and  for 5 seconds to unlock the buttons, press , enter program set mode, through  and  buttons to select “Advanced Setting”, press , enter “Advanced Setting” item setting mode, through  and  buttons to select “Set Residual Water”, press , through  and  to set the required value. Press  and hear a sound “Di”, then finish the adjustment. Press  twice, and turn back to Service status.

The regeneration parameters have been set when control valve left factory. Generally, it does not need to reset. If you want to enquiry and modify the setting, you can refer to the professional application specifications.

3. Applications

3.1. Softener Flow Chart

Take F79A as example. (For F79B, the entire regeneration cycle, including Backwash, Brine & Slow Rinse, Brine Refill and Fast Rinse, has hard water passing the outlet of valve.)

■ Working Process and Principle

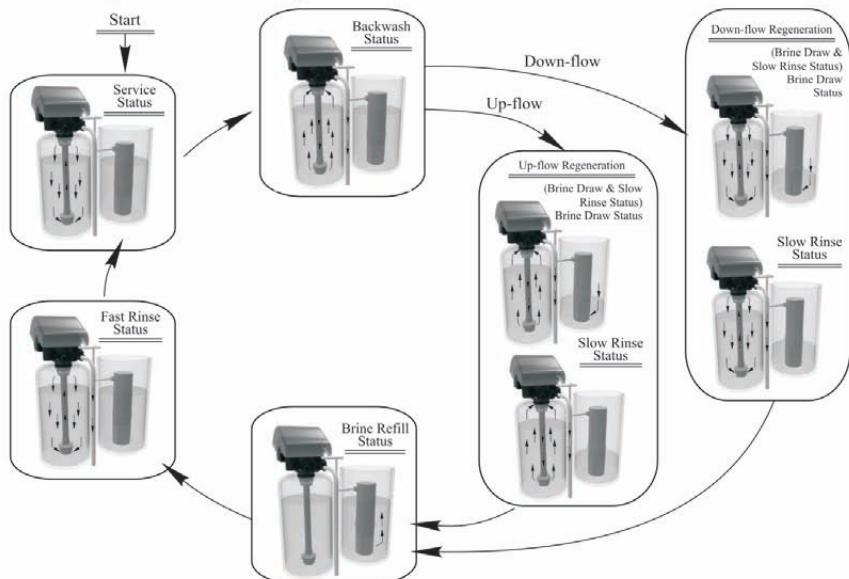

3.2. The Function and Connection of PC Board

Open the front cover of control valve, you will see the main control board and connectors as below:

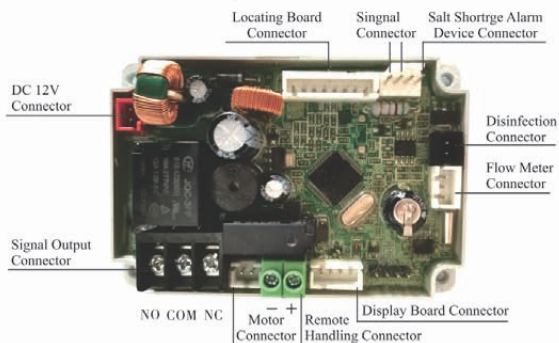

The main functions on main control board:

Function	Application	Explanation
Signal Output Connector b-01	Outlet solenoid valve	Used in strict requirements regarding no hard water flowing from outlet or control the liquid level controller in water tank.
	Inlet pump	Increase pressure for regeneration or washing. Use the liquid level controller to control inlet pump to ensure there is water in tank.
Signal Output Connector b-02	Inlet solenoid valve or inlet pump	When inlet pressure is high, it needs to close water inlet to protect motor when valve is rotating.
Disinfection Connector	It is used for disinfecting resin when softener in regeneration.	Under the Brine & Slow Rinse status, it can make a part of brine electrolyzed, and produce hypochlorous acid to sterilize and disinfect the resin.
Connector of Salt Shortage Alarm	It is used for checking whether the salt is enough in the brine tank.	When the brine tank is short of salt, the system will give the alarm and remind user to add the salt in time.
Remote Handling Connector	Receipt signal to make the control valve rotate to next status.	It is used for on-line inspection system, connected with PC to realize automatic or remote controlling of valve.

A. Signal Output Connector

1) Control Outlet Solenoid Valve (Set b-01)

① Solenoid Valve on Outlet Controls Water Level in Water Tank.

Instruction: If system requires no hard water flowing from outlet in regeneration cycle (Mainly for no hard water flows out automatically when valve is switching or valve in backwash or brine drawing status), a solenoid valve could be installed on outlet, the wiring refers to Figure 3-1.

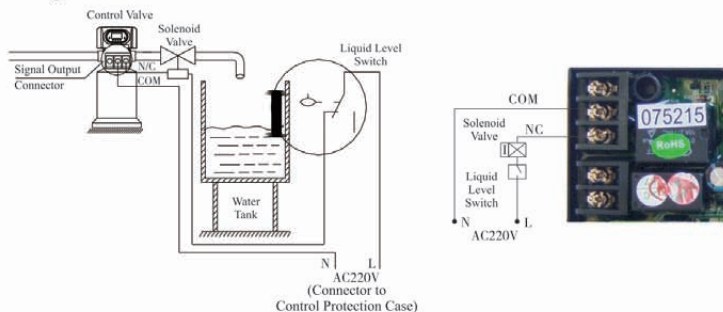

Figure 3-1 Wiring of Solenoid Valve on Outlet

Function:

When valve is in service status, if soft water tank is short of water, solenoid valve will open to supply soft water. But if water tank has enough water, solenoid valve will close, so no soft water will be supplied into soft water tank.

When the valve is in backwash or other regeneration status, there is no signal output. So solenoid valve will close, and no raw water flows into soft water tank.

②Control Inlet Solenoid Valve (Set b-02)

Instruction: When inlet pressure exceeds 0.6MPa, install a solenoid valve on inlet. Control mode is b-02. Pressure is relieved when valve switching, the wiring refers to Figure 3-2. As Figure 3-3 shows, it also can use the pressure relief connector to work.

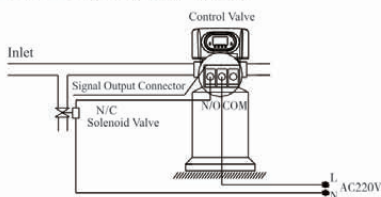
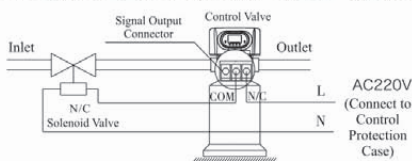

Figure 3-2 Wiring of Solenoid Valve on Inlet

Figure 3-3 Wiring of Pressure Relief Connector

Function:

When inlet pressure is high, install a solenoid valve on inlet to ensure valve switching properly. When valve is exactly at status of Service, Backwash, Brine & Slow Rinse, Brine Refill and Fast Rinse, solenoid valve is open. When valve is switching, solenoid valve is closed, no water flows into valve to ensure valve switching properly. It could prevent the problem of mixing water and water hammer.

Use interlock cable to realize valves in parallel and series in same system which is suited for RO pretreatment system or second grade Na⁺ system. The wiring refers to Figure 3-4:

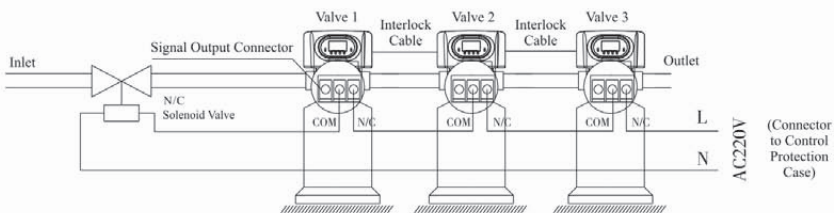

Figure 3-4 Wiring of Solenoid Valve on Inlet

2) Liquid Level Controller Controls Inlet Pump (Two-phase motor) (Set b-01)

Instruction: For the system using well or middle-tank supplying water, switch of liquid level controller and valve together control pump opening or closing. The wiring refers to Figure 3-5:

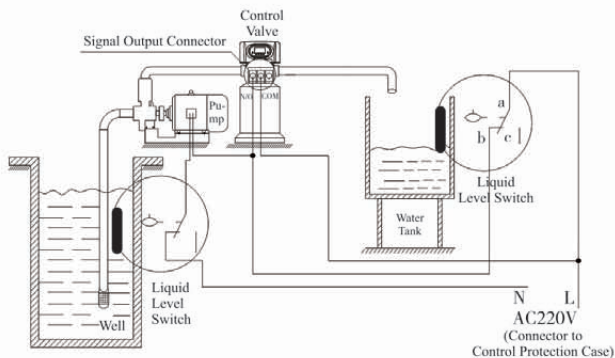

Figure 3-5 Wiring of Liquid Level Controller Controlling Inlet Pump

Function:

When valve is in service status, if water tank is short of water, pump starts working; if not, the switch of liquid level controller is closed, so pump doesn't work.

When valve is in backwash or other regeneration status, no matter what is water condition in water tank, open the pump to make sure there is water on inlet. As there is no water flows out of outlet in regeneration cycle, it ensures no water fills into water tank. A liquid level controller at the top opening of well or in middle water tank in RO system can protect pump from working without water in case of out of raw water.

3) Liquid Level Controller in Water Tank Controls Inlet Pump (Three-phase) (Set b-01)

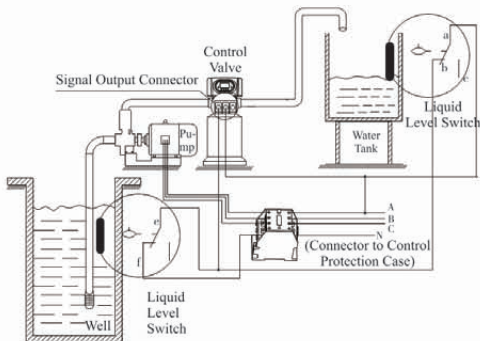

Figure 3-6 Wiring of Liquid Level Switch in Water Tank Controls Inlet Pump

4) Control Inlet Booster Pump (Set b-01 or b-02)

Instruction: If inlet water pressure is less than 0.15MPa, which makes backwash or brine drawing difficult, a booster pump is suggested to be installed on inlet. Control mode set to b-01. When system in regeneration cycle, booster pump is open, the wiring refers to Figure 3-7. If the booster pump current is bigger than 5A, the system needs to install a contactor, the wiring refers to Figure 3-8.

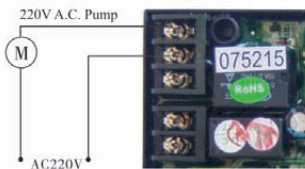

Figure 3-7 Wiring of Booster Pump on Inlet

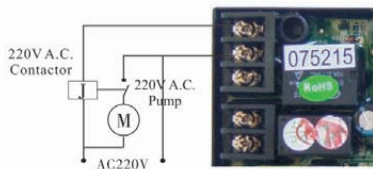

Figure 3-8 Wiring of Booster Pump on Inlet

B. Disinfection Device Connector

If it is need to connect with disinfection device, the ground electrode of the disinfection device and positive power should be connected to the “GND” and “+5V” separately in disinfection device connector. The wiring refers to the Figure 3-9.

C. Salt Shortage Alarm Device

If it is need to connect with salt shortage alarm device, the ground electrode of the salt shortage alarm device and positive power should be connected to the “GND” and “+12V” separately in salt shortage alarm device connector, the switches of the device should be connected to the “GND” and “UPCH” separately. The wiring refers to the Figure 3-10.

Connect to the ground electrode of the disinfection device.
Connect to positive power of the disinfection device.



Figure 3-9

Connect to positive power of salt shortage alarm device.

Connect to the ground electrode of salt shortage alarm device.

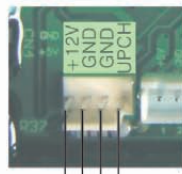

Connect to the switches of salt shortage alarm device.

Connect to the switches of salt shortage alarm device.

Figure 3-10

D. Remote Handling Connector

When the valve is used to make pure water or other system that can be monitored online or connected to a PC, etc., when the conductivity or other parameters reach the set value or the PC sends a signal and needs system regeneration, it can be provide a signal to remote handling connector of main control board by the signal line, which can make the valve regenerate immediately. The connector receiving the signal is equivalent to pressing the manual button. The wiring refers to Figure 3-11:

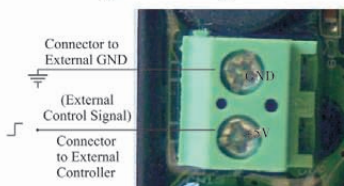

Figure 3-11 Wiring of Remote Handling Connector

3.3. System Configuration and Flow Rate Curve

A. Product Configuration

Product configuration with tank, resin volume, brine tank and injector

Tank Size (mm)	Resin Volume (L)	Flow Rate (t/h)	Brine Tank Size (mm)	The Minimum Salt Consumption for Regeneration(Kg)	Injector Model (Old/New)
φ180×1130	16	0.5	φ250×520	2.4	6302/6801
φ205×1300	25	0.7	φ390×810	4.0	6303/6802
φ255×1390	40	1.2	φ390×810	6.0	6305/6804
φ300×1650	60	1.8	φ450×940	9.0	6306/6806
φ355×1650	100	2.5	φ500×1060	15.0	6308/6808
φ400×1650	120	3.5	φ550×1160	18.0	6309/6809
φ450×1650	150	4.5	φ550×1160	22.5	6310/6810

Note: ① The flow rate calculation is based on linear velocity 25m/h; the minimum salt consumption for regeneration calculation is based on salt consumption 150g/L (Resin).

②The above configuration is applicable to industrial sodium ion exchanger, specifications and parameters are for reference only.

B. Flow Rate Characteristic

1) Pressure-flow rate curve

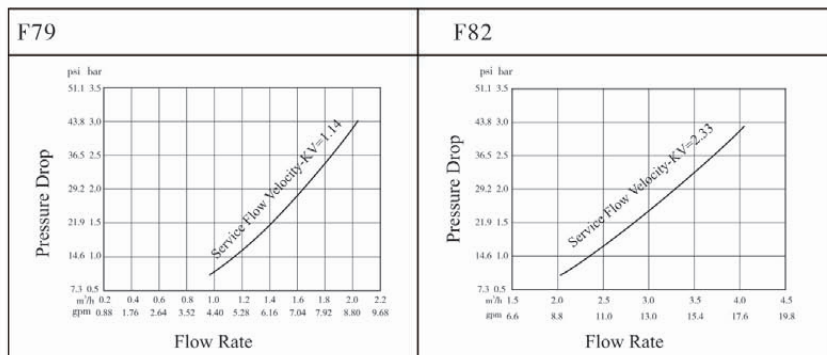

2) Injector Parameter Table

Old Injector: (6300 series)

Inlet Pressure	Draw Rate (L/M)									
	6301 Coffee	6302 Pink	6303 Yellow	6304 Blue	6305 White	6306 Black	6307 Purple	6308 Red	6309 Green	6310 Orange
0.15	0.81	1.12	1.58	2.21	2.45	3.30	3.44	4.08	5.19	5.69
0.20	0.95	1.41	1.87	2.53	2.89	3.88	4.21	4.83	5.36	6.80
0.25	0.99	1.61	2.08	2.79	3.30	4.30	4.66	5.39	6.86	7.65
0.30	1.30	1.81	2.18	3.05	3.66	4.74	5.15	5.95	7.50	8.60
0.35	1.45	1.96	2.39	3.27	3.94	5.02	5.55	6.51	8.30	9.57
0.40	1.56	2.12	2.55	3.50	4.25	5.41	5.88	6.77	8.74	9.90

New Injector: (6800 series)

Inlet Pressure	Draw Rate/Slow Rinse Rate (L/M)											
	6820 Grey	6821 Cyan	6801 Coffee	6802 Pink	6803 Yellow	6804 Blue	6805 White	6806 Black	6807 Purple	6808 Red	6809 Green	6810 Orange
0.15	0.61/ 0.48	0.88/ 0.63	1.30/ 0.76	1.45/ 1.17	2.00/ 1.65	2.68/ 2.28	2.72/ 2.67	3.72/ 3.11	4.52/ 3.55	4.85/ 3.86	5.75/ 4.71	6.00/ 4.78
0.20	0.70/ 0.56	1.03/ 0.74	1.52/ 0.87	1.73/ 1.38	2.37/ 1.84	3.16/ 2.54	3.27/ 2.93	4.27/ 3.40	5.03/ 3.81	5.70/ 4.25	6.40/ 5.15	6.26/ 5.41
0.25	0.79/ 0.60	1.14/ 0.83	1.77/ 0.98	1.90/ 1.47	2.70/ 1.97	3.46/ 2.71	3.78/ 3.13	4.80/ 3.68	5.65/ 4.11	6.22/ 4.61	7.19/ 5.57	7.13/ 5.89

0.30	0.87/ 0.65	1.27/ 0.91	1.93/ 1.06	2.26/ 1.56	3.00/ 2.12	3.80/ 2.91	4.30/ 3.39	5.23/ 3.93	6.20/ 4.43	6.80/ 4.88	7.97/ 6.00	8.53/ 6.51
0.35	0.95/ 0.72	1.35/ 0.99	2.08/ 1.12	2.20/ 1.67	3.23/ 2.23	4.05/ 3.09	4.50/ 3.62	5.57/ 4.17	6.67/ 4.71	7.27/ 5.16	8.50/ 6.27	8.80/ 6.97
0.40	1.00/ 0.77	1.43/ 1.05	2.23/ 1.14	2.27/ 1.75	3.46/ 2.35	4.38/ 3.24	4.88/ 3.78	5.95/ 4.35	6.95/ 4.99	7.63/ 5.41	8.80/ 6.66	9.30/ 7.28

3) Configuration for Standard Injector and Drain Line Flow Control

Old injector configuration:(6300 series)

Tank Dia. (mm)	Injector Model	Injector Color	Draw Rate	Slow Rinse Rate	Brine Refill Rate	DLFC	Backwash / Fast Rinse Rate
			L/m	L/m	L/m		L/m
150	6301	Coffee	1.30	0.91	3.00	1#	4.70
175	6302	Pink	1.81	1.32	3.70	1#	4.70
200	6303	Yellow	2.18	1.73	3.80	2#	8.00
225	6304	Blue	3.05	2.14	3.30	2#	8.00
250	6305	White	3.66	2.81	4.30	3#	14.40
300	6306	Black	4.74	3.32	4.20	3#	14.40
325	6307	Purple	5.15	3.55	4.10	4#	22.80
350	6308	Red	5.95	4.00	4.00	4#	22.80
400	6309	Green	7.50	5.13	4.00	5#	26.40
450	6310	Orange	8.60	5.98	3.90	5#	26.40

New injector configuration: (6800 series)

Tank Dia. (mm)	Regeneration Way	Injector Code	Nozzle / Throat Type	Nozzle / Throat / Plug Color	BLFC Code		DLFC Code
					Standard	Optional	
150	Down-flow	5468237	6821	Cyan	8468057	8468076, 8468075	8468064
	Up-flow	5468247	6820	Grey			
175	Down-flow	5468238	6801	Coffee	8468057	8468076, 8468075	8468043
	Up-flow	5468248	6821	Cyan			
200	Down-flow	5468239	6802	Pink	8468056	8468076, 8468075, 8468057	8468042
	Up-flow	5468249	6821	Cyan			
225	Down-flow	5468240	6803	Yellow	8468056	8468076, 8468075, 8468057	8468060
	Up-flow	5468250	6801	Coffee			
250	Down-flow	5468241	6804	Blue	8468052	8468076, 8468075, 8468057, 8468056	8468061
	Up-flow	5468251	6802	Pink			
300	Down-flow	5468242	6806	Black	8468053	8468076, 8468075, 8468057, 8468056, 8468052	8468077
	Up-flow	5468252	6803	Yellow			

325	Down-flow	5468243	6807	Purple	8468053	8468076, 8468075, 8468057, 8468056, 8468052	8468044
	Up-flow	5468253	6804	Blue			
350	Down-flow	5468244	6808	Red	8468054	8468076, 8468075, 8468057, 8468056, 8468052, 8468053	8468062
	Up-flow	5468254	6805	White			
400	Down-flow	5468245	6809	Green	8468055	8468076, 8468075, 8468057, 8468056, 8468052, 8468053, 8468054	8468063
	Up-flow	5468255	6806	Black			
450	Down-flow	5468246	6810	Orange	8468055	8468076, 8468075, 8468057, 8468056, 8468052, 8468053, 8468054	Without DLFC
	Up-flow	5468256	6807	Purple			

Note: The above configuration is suitable for industrial use. The actual configuration should be based on different raw water hardness and different water requirements. If it is used for civil and household purposes, considering the small height diameter ratio of resin bed, the optimal configuration should be selected after experimental verification, and it is recommended to use a smaller salt absorption regeneration flow rate(1~2m/h).

4). BLFC Parameter Table (Only for 6800 Injector)

Part Number	8468076	8468075	8468057	8468056	8468052	8468053	8468054	8468055	
Color	Red	Purple	Black	White	Coffee	Pink	Yellow	Blue	
Flow Rate	L/m	0.38	0.68	0.98	1.21	1.66	2.73	4.92	5.86
	gal/min	0.10	0.18	0.26	0.32	0.44	0.72	1.30	1.55

5). DLFC Parameter Table (Only for 6800 Injector)

Part Number	8468064	8468043	8468042	8468060	8468061	8468045	8468077	8468044	8468062	8468063	No DLFC	
Color	Green	Pink	Coffee	White	Black	Blue	Orange	Yellow	Purple	Red	/	
Flow Rate	L/m	3.33	4.31	7.15	7.64	10.82	15.96	18.10	18.50	24.97	30.64	32.00
	gal/min	0.88	1.14	1.89	2.02	2.86	4.22	4.78	4.89	6.60	8.10	8.45

Note: The above configuration for the product and relevant characteristics are only for reference. When put in practice, it is subject to the different requirements of raw water hardness and application.

3.4. Parameter Settlement

① Service Time T1

Water Treatment Capacity:

$$Q = V_R \times K \div Y_D (\text{m}^3)$$

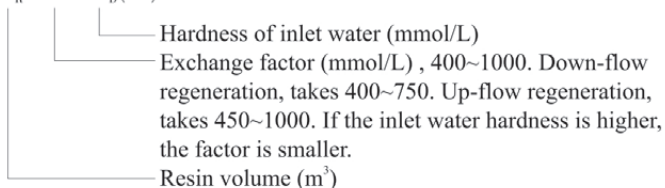

By hours: $T1 = Q \div Q_h$ (Hour)

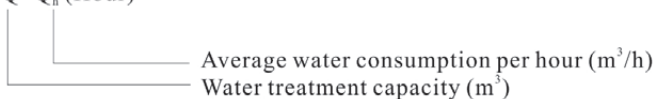

By days: $T1 = Q \div Q_d$ (Day)

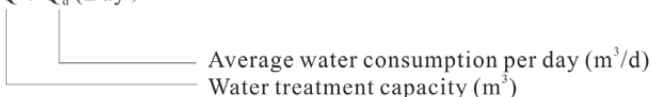

② Backwash Time T2

Generally, it is suggested to set 10~15 minutes. The higher the turbidity is, the longer backwash time can be set. However, if the turbidity is more than 5 FTU, it should be better to install a filter in front of the exchanger.

③ Brine & Slow Rinse Time T3

$$T3 = (40 \sim 50) \times H_R (\text{min.})$$

Generally, $T3 = 45 H_R$ (min.)

In this formula, H_R — The height of resin in exchange tank (m).

④ Brine Refill Time T4

Down-flow regeneration: $T4 = 0.45 \times V_R \div \text{Brine refill speed}$

Up-flow regeneration: $T4 = 0.34 \times V_R \div \text{Brine refill speed}$

In this formula, V_R — Resin volume (m^3)

The brine refill speed is related to inlet water pressure. It is suggested to be 1~2 minutes longer than the calculated brine refilling time to make sure there is enough water in tank. (The brine tank should be equipped with liquid level controller)

⑤ Fast Rinse Time T5

$$T5 = 12 \times H_R (\text{min.})$$

Generally, the water for fast rinse is 3~6 times of resin volume. It is suggested to be set 10~16 minutes. But it should meet the requirements of qualified outlet water.

⑥Exchange Factor

$$\text{Exchange factor} = E / (k \times 1000)$$

In this formula, E—Resin working exchange capability (mol / m^3), it is related to the quality of resin. Down-flow regeneration, takes 800~900. Up-flow regeneration, takes 900~1200.

K—Security factor, always takes 1.2~2. It is related to the hardness of inlet water: the higher the hardness is, the bigger the K is.

⑦Set Up Interval Backwash Times (Only for up-flow regeneration mode)

When the turbidity of raw water is higher, the interval backwash times could be set F-00. That is to say, backwash in each regeneration; when the turbidity is lower, the interval backwash times could be set F-01 (or other number value), it is to say that backwash in every two regeneration. Thus, Service → Brine & slow rinse → Brine refill → Fast rinse → Service → Backwash → Brine & slow rinse → Brine refill → Fast rinse.

⑧Regeneration Time: The whole cycle for regeneration is about two hours. According to the actual situation, please try to set up the regeneration time when you don't need to use water.

The above calculation of parameters for each step is only for reference, the actual proper time will be determined after adjusting by water exchanger supplier. This calculation procedure of softener is only for industrial application; it is not suitable for small softener in residential application.

3.5. Parameter Enquiry and Setting

3.5.1. Parameter Enquiry

When lights on, press and hold both and for 5 seconds to unlock the button; then press to enter the program display mode; choose the enquiry item, press to view each value. According to below process to enquiry each value. (Press twice back to service status.)

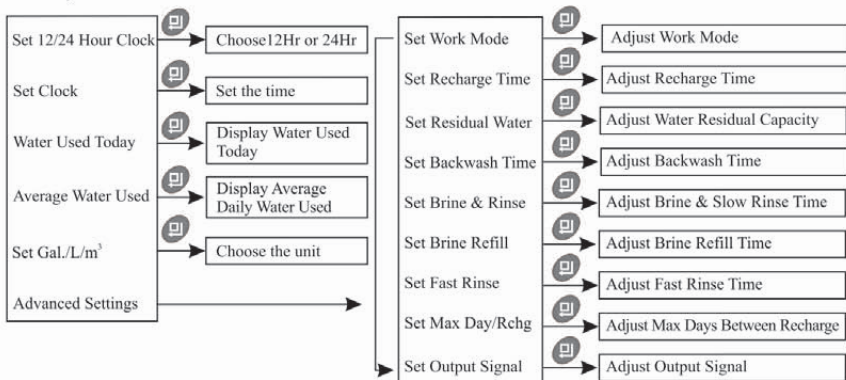





















































































































3.5.2. Parameter Setting









In program display mode, press or to adjust the value.

3.5.3 The steps of parameter setting













Items	Process steps	Symbol
Set 12/24 Hour Clock	<p>When lights on, press and hold and for 5 seconds until the lights off.</p> <ol style="list-style-type: none"> Press to enter into the setting interface. The option of “Set 12/24 Hour Clock” will be selected by system automatically. Then press , the setting interface will display as the right figure. Through or to adjust hour clock. Lastly, press and hear a sound “Di”, then finish adjustment. 	<p>Set 12/24 Hour Clock:</p> <ul style="list-style-type: none"> <input type="radio"/> 12 Hour <input checked="" type="radio"/> 24 Hour
Set Clock	<ol style="list-style-type: none"> In setting status, press or to select “Set Clock”. Press , the setting interface will display as the right figure. Then press or to set the time. Lastly, press and hear a sound “Di”, then finish adjustment. 	<p>Set Clock:</p> <p>12:12</p> <ul style="list-style-type: none"> OK Cancel Change

Water Used Today	In setting status, press  or  to select “Water Used Today”, you can see the value.	Water Used Today: 0.00m ³  Back
Average Daily Water Used	In setting status, press  or  to select “Average Daily Water Used”, you can see the value.	Average Daily Water Used:0.00m ³  Back
Set Gal./L/ m ³	1. In setting status, press  or  to select “Set Gal./L/ m ³ ”. 2. Press  , the setting interface will display as the right figure. Then press  or  to choose the unit. 3. Lastly, press  and hear a sound “Di”, then finish the adjustment.	Set Gal./L/ m ³ : <input type="radio"/> U.S Gallons <input type="radio"/> Liters <input checked="" type="radio"/> m ³
Work Mode	1. In advanced setting status, press  , then press  or  to select “Set Work Mode”. 2. Press  , work mode setting show as right figure. Then press  or  to choose the available control mode. 3. Lastly, press  and hear a sound “Di”, then finish adjustment.	Set Work Mode: (A-03) <input type="radio"/> Delayed/Down-flow <input type="radio"/> Immediate/Down-flow <input type="radio"/> Intelligent/Down-flow <input type="radio"/> Delayed/Up-flow <input type="radio"/> Immediate/Up-flow <input type="radio"/> Intelligent/Up-flow <input type="radio"/> Purify
Recharge Time	1. In advanced setting status, press  , then press  or  to select “Set Recharge Time”. 2. Press  , recharge time setting show as right figure. Then press  or  can set the recharge time. 3. Lastly, press  and hear a sound “Di”, then finish adjustment.	Set Recharge Time: 02:00 (Hour:Min)  OK  Cancel   Change
Residual Water Capacity	1. In advanced setting status, press  or  to select “Residual Water Capacity”. 2. Press  , residual water capacity setting show as right figure. Then press  or  to set the residual water capacity. 3. Lastly, press  and hear a sound “Di”, then finish adjustment.	Set Residual Water Capacity: 10:00 m ³  OK  Cancel   Change
Interval Backwash Times	1. In advanced setting status, press  , then press  or  to select “Interval Backwash Times”. 2. Press  , interval backwash times setting show as right figure. Then press  or  to adjust the interval backwash times . 3. Lastly, press  and hear a sound “Di”, then finish adjustment.	Set Interval Backwash Times: 00 (F-00)  OK  Cancel   Change

Repeat-Washing Times	<ol style="list-style-type: none"> 1. In advanced setting status, press , then press  or  to select "Repeat-Washing Times". 2. Press , repeat-washing times setting show as right figure. Then press  or  to adjust the repeat-washing times. 3. Lastly, press  and hear a sound "Di", then finish adjustment. 	Set Repeat-Washing Times: 00 (F-00)  OK  Cancel   Change
Backwash Time	<ol style="list-style-type: none"> 1. In advanced setting status, press , then press  or  to select "Set Backwash Time". 2. Press , backwash time setting show as right figure. Then press  or  to adjust the backwash time. 3. Lastly, press  and hear a sound "Di", then finish adjustment. 	Set Backwash Time: 10:00 (Min:Sec)  OK  Cancel   Change
Brine & Slow Rinse Time	<ol style="list-style-type: none"> 1. In advanced setting status, press , then press  or  to select "Set Brine & Slow Rinse Time". 2. Press , brine & slow rinse time setting show as right figure. Then press  or  to adjust the brine time. 3. Lastly, press  and hear a sound "Di", then finish adjustment. 	Set Brine & Slow Rinse Time:60:00 (Min:Sec)  OK  Cancel   Change
Brine Refill Time	<ol style="list-style-type: none"> 1. In advanced setting status, press , then press  or  to select "Set Brine Refill Time". 2. Press , brine refill time setting show as right figure. Then press  or  to adjust the refill time. 3. Lastly, press  and hear a sound "Di", then finish adjustment. 	Set Brine Refill Time:05:00 (Min:Sec)  OK  Cancel   Change
Fast Rinse Time	<ol style="list-style-type: none"> 1. In advanced setting status, press , then press  or  to select "Set Fast Rinse Time". 2. Press , fast rinse time setting show as right figure. Then press  or  to adjust the fast rinse time. 3. Lastly, press  and hear a sound "Di", then finish adjustment. 	Set Fast Rinse Time:10:00 (Min:Sec)  OK  Cancel   Change
Max Days Between Recharges	<ol style="list-style-type: none"> 1. In advanced setting status, press , then press  or  to enter into "Max Days Between Recharges". 2. Press , max days between recharges setting show as right figure. Then press  or  to adjust the days. 3. Lastly, press  and hear a sound "Di", then finish adjustment. 	Set Max Days Between Recharges:30 Day  OK  Cancel   Change



Output Signal Mode	<ol style="list-style-type: none"> 1. In advanced setting status, press , then press  or  to select "Set Output Signal". 2. Press , output signal mode setting show as right figure. Then press  or  to adjust the mode. 3. Lastly, press  and hear a sound "Di", then finish adjustment. 	<div style="border: 1px solid black; padding: 5px; text-align: center;"> Set Output Signal b-01 b-02 </div>
--------------------	-------------------------------------------------------------------------------------------------------------------------------------------------------------------------------------------------------------------------------------------------------------------------------------------------------------------------------------------------------------------------------------------------------------------------------------------------------------------------------------------------------------------------------------------------------------------------------------------------------------------------------------------------------------------------------------------------------------------------------------------------------------------------------------------------------------------------------------------------------------------------------------------------------------------	-----------------------------------------------------------------------------------------------------------------------------------------------------------------------------------------------------------------------------------------------------------------------------------------------------------

For example, the fast rinse time of a softener is 12 minutes. After regenerating, the chloridion in the outlet water is always higher than normal, indicating that there is not enough time for fast rinse. If you want to set the time to 15 minutes, the modification steps as follows:

- ① Press and hold both  and  to unlock the button ( lights off).
- ② Press , enter into the setting status.
- ③ Press  or  to select "Advanced Setting" first.
- ④ Press  to enter into advanced setting menu.
- ⑤ Press  or  to select "Setting Fast Rinse".
- ⑥ Press  to enter into "Set Fast Rinse Time" interface.
- ⑦ Press  or  change 12 to 15.
- ⑧ Press  and hear a sound "Di", then the program back to enquiry status. If you want to adjust other parameters, you can adjust as above steps.

3.6. Trial Running

After installing the multi-functional flow control valve on the resin tank with the connected pipes, as well as setting up the relevant parameters, please conduct the trail running as follows:

- A. Close inlet/outlet valve B and Valve C, open bypass valve A, clean the impurity in the pipe, and then close bypass valve A (as Figure 3).
- B. Add calculated water to the brine tank and adjust the air check valve. Then add solid salt to the brine tank and dissolve the salt as much as possible.
- C. Switch on power. Press  and enter into the backwash status; slowly open the inlet valve B to 1/4 position, making the water flows into the resin tank; you can hear the sound of air-out from the drain pipeline. After all air is out of pipeline, then open inlet valve B completely and clean the impurity in the resin tank until the outlet water is clean. It will take 8~10 minutes to finish the whole process.
- D. Press , and turn the status from backwash to brine & slow rinse. Enter in the process of brine & slow rinse. The air check valve will close when control valve finished sucking brine, then slow rinse starts to work. It is about 60~65 minutes for whole process.
- E. Press  to brine refill status, the brine tank is being refilled with water to the required level. It takes about 5~6 minutes, then add solid salt to the brine tank.

F. Press , and turn to fast rinse status and start to fast rinse. After 10~15 minutes, take some outlet water for testing: If the water hardness reaches the requirement, and the content of chloridion in the outlet water is almost same as the inlet water, then the valve can go to the next step.

G. Press , make the control valve return to service status and start running.

Note:

- When the control valve enters into the regeneration status, all programs can be finished automatically according to the setting time; if you want one of steps to be terminated early, you can press  .
- If water inflows too fast, the media in tank will be damaged. When water inflows slowly, there is a sound of air emptying from drain pipeline.
- After changing resin, please empty air in the resin according to above Step C.
- In the process of trial running, please check the water situation in all status, ensuring there are no resin leakage.
- The time for Backwash, Brine & Slow Rinse, Brine Refill and Fast Rinse status can be set and executed according to the calculation in the formula or suggestions from the control valve suppliers.

3.7. Trouble-Shooting

A. Control Valve Fault

Problem	Cause	Correction
1. Softener fails to regenerate.	A. Electrical service has been interrupted. B. Regeneration time set incorrect. C. Controller damaged. D. Motor fails to work.	A. Assure permanent electrical service (Check fuse, plug, switch and so on). B. Reset regeneration time. C. Replace controller. D. Replace motor.
2. Regeneration time is not correct.	A. Time of day does not set correctly. B. Power failure more than 3 days.	A. Check program and reset time of day. B. Reset time of day.
3. Softener supplies hard water.	A. Bypass valve is open or leaking. B. No salt in brine tank. C. Injector plugged. D. Insufficient water flows into brine tank. E. O-ring on riser pipe leaks. F. Interior of valve leaks. G. Regeneration cycles are not correct or raw water quality deterioration. H. Shortage of resin. I. Bad quality of raw water or impeller blocked. J. Adjusting bolt is open.	A. Close or repair bypass valve. B. Make sure there is solid salt in the brine tank. C. Change or clean injector. D. Check brine tank refill time. E. Make sure riser pipe is not cracked. Check o-ring and tube pilot. F. Check and repair valve body. G. Set correct regeneration time or water capacity. H. Add resin to resin tank and check whether resin leaks. I. Reduce the inlet turbidity, clean or replace flow meter. J. Close the adjusting bolt.

Control Valve Fault (Continued)

<p>4. Softener fails to draw brine.</p>	<p>A. Inlet pressure is too low. B. Brine line plugged. C. Brine line leaks. D. Injector plugged or damaged. E. Interior of valve leaks. F. Drain line plugged. G. Sizes of injector and DLFC are not matched with tank.</p>	<p>A. Increase inlet pressure. B. Clean brine line. C. Clean brine line. D. Clean or replace injector. E. Repair or replace valve body. F. Check drain line. G. Select correct injector size and DLFC according to the instruction requirements.</p>
<p>5. Unit used too much salt.</p>	<p>A. Improper salt setting. B. Excessive water in brine tank.</p>	<p>A. Check salt usage and salt setting. B. See problem No.6.</p>
<p>6. Excessive water in brine tank.</p>	<p>A. Overlong brine refill time. B. Excess water left after brine draw. C. Foreign material in liquid level controller. D. Not install liquid level controller and power failure in brine status. E. Brine refill is uncontrolled</p>	<p>A. Reset correct brine refill time. B. Check the injector and make sure no stuff in the brine pipe. C. Clean liquid level controller. D. Stop water supplying, and restart or install liquid level controller in salt tank when power restored. E. Repair or replace liquid level controller.</p>
<p>7. Pressure lost or the pipe rusted.</p>	<p>A. Iron scale in the water supply pipe. B. Iron scale accumulated in the softener. C. Fouled resin bed. D. Too much iron in the raw water.</p>	<p>A. Clean the water supply pipe. B. Clean valve and add resin cleaning chemical, increase frequency of regeneration. C. Check backwash, brine draw and brine tank refill. Increase frequency of regeneration and backwash time. D. Iron removal equipment is required to install before softening.</p>
<p>8. Resin discharged through drain pipe</p>	<p>A. Air in water system. B. Strainer broken. C. Large drain flow rate when backwash.</p>	<p>A. Empty the air from the system. B. Replace new strainer. C. Check and adjust proper drain rate.</p>
<p>9. Control valve cycle continuously.</p>	<p>A. Locating signal wire breakdown. B. Controller is faulty. C. Foreign material stuck the driving gear. D. Time of regeneration steps were set to zero.</p>	<p>A. Check and connect locating signal wire. B. Replace controller. C. Take out foreign material. D. Check program setting and reset.</p>
<p>10. Drain flows continuously.</p>	<p>A. Interior of valve leaks. B. Power off when in backwash or fast rinse.</p>	<p>A. Check and repair valve body or replace it. B. Adjust valve to service status or turn off bypass valve and restart when electricity supply.</p>
<p>11. Interrupted or irregular brine draw.</p>	<p>A. Water pressure is too low or not stable. B. Injector is plugged or damaged. C. Air in resin tank. D. Floccules in resin tank during up-flow regeneration.</p>	<p>A. Increase water pressure. B. Clean or replace injector. C. Check and find the reason. D. Clean the floccules in resin tank.</p>
<p>12. Water flows out from drain or brine pipe after regeneration.</p>	<p>A. Foreign material in valve which makes valve can't be closed completely. B. Hard water mixed in valve body. C. Water pressure is too high which results in valve not getting the right status.</p>	<p>A. Clean foreign material in valve body. B. Change valve core or sealing ring. C. Reduce water pressure or use pressure release function.</p>

Control Valve Fault (Continued)

13. Salt water in outflow pipe.	A. Foreign material in injector or injector fails to work. B. Brine valve can't be shut-off. C. Fast rinse time is too short.	A. Clean and repair injector. B. Repair brine valve and clean it. C. Extend fast rinse time.
14. Water capacity decreases.	A. Regenerate not properly. B. Fouled resin bed. C. Salt setting is not proper. D. Softener setting is not proper. E. Raw water quality deteriorated. F. Impeller has already gotten stuck.	A. Regenerate according to the right way. B. Increase backwash flow rate and time, clean or change resin. C. Reset the appropriate amount of salt D. According to the test of outlet water, recount and reset. E. Regenerate by manual temporarily then reset regeneration cycle. F. Disassemble flow meter and clean it, or replace it with a new flow meter.

B. Controller Fault

Problem	Cause	Correction
1. Incorrect display on display board.	A. Wiring of display board with control board fails to work. B. Control board damaged. C. Transformer damaged. D. Electrical service not stable.	A. Check and replace the wiring. B. Replace control board. C. Check and replace transformer. D. Check and adjust electrical service.
2. No display on display board.	A. Wiring of display board with control board fails to work. B. Display board damaged. C. Control board damaged. D. Electricity is interrupted.	A. Check and replace wiring. B. Replace display board. C. Replace control board. D. Check electricity.
3. E1 Flashes	A. Wiring of locating board with control board fails to work. B. Locating board damaged. C. Mechanical driven failure. D. Control board damaged. E. Wiring of motor with control board is fault. F. Motor damaged.	A. Replace wiring. B. Replace locating board. C. Check and repair mechanical part. D. Replace control board. E. Replace wiring. F. Replace motor.
4. E2 Flashes	A. Hall component on locating board damaged. B. Wiring of locating board with control board fails to work. C. Control board damaged.	A. Replace locating board. B. Replace wiring. C. Replace control board.
5. E3 or E4 Flashes	A. Control board damaged.	A. Replace control board.

3.8 . Assembly & Parts

F79A-LCD/F79B-LCD Valve Body Assembly

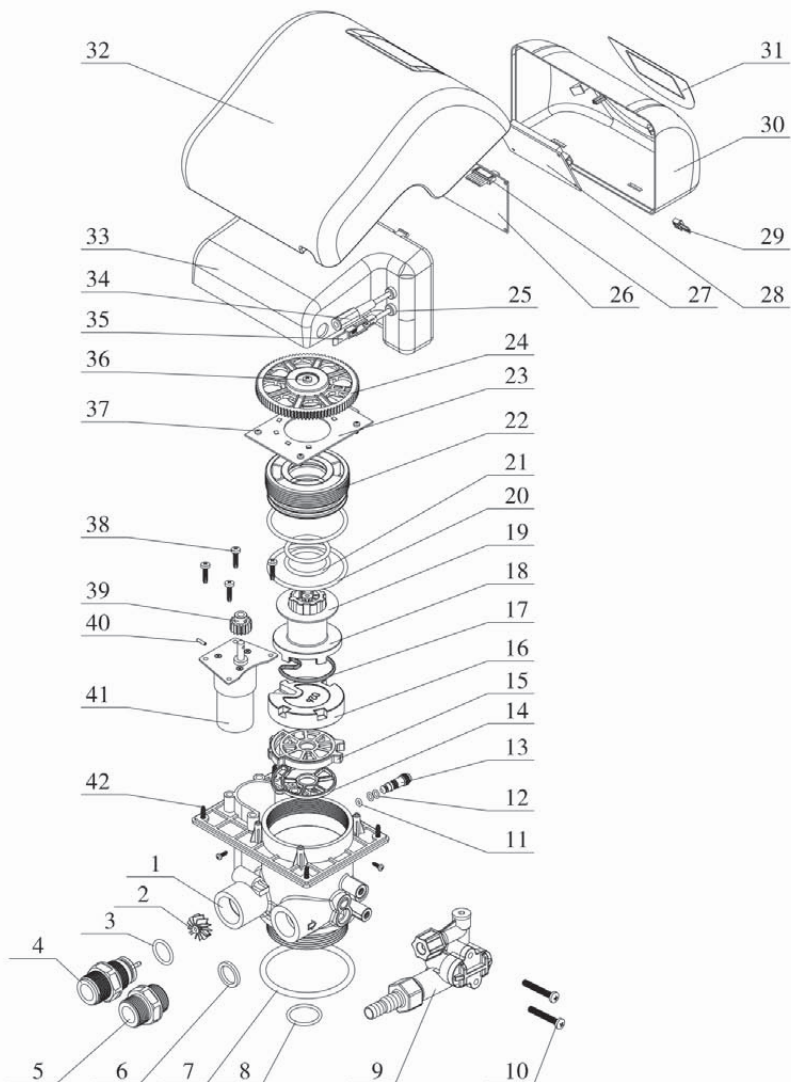

F79A-LCD/F79B-LCD Valve Body Components

Item No.	Description	Part No.	Quantity	Item No.	Description	Part No.	Quantity
1	Valve Body	5022029	1	22	Fitting Nut	8092011	1
2	Impeller	5436007	1	23	Locating Board	6380011	1
3	O-ring	8378075	1	24	Gear	5241009	1
4	Flow Meter Connector	8458026	1	25	Cable Clip	8126004	2
5	Connector	8458011	1	26	Control Board	6382138	1
6	Seal Ring	8371019	1	27	Wire for Locating Board	5511004	1
7	O-ring	8378160	1	28	Display Board	6381006	1
8	O-ring	8378175	1	29	Wire for Display Board	5512002	1
9	6300 Injector	5468005	1	30	Front Cover	8300008 (8300004)	1
	6800 Injector	Selection		31	Label	8865014 (8865013)	1
10	Screw, Cross	8902017	2	32	Weather Cover	8300015	1
11	O-ring	8378183	1	33	Dust Cover	8005013 (8005014)	1
12	O-ring	8378174	2	34	Wire for Power	5513003	1
13	Adjust Screw	8906002	1	35	Probe Wire	6386001	1
14	Seal Ring	8370047	1	36	Screw, Cross	8909013	1
15	Fixed Disk	8469024	1	37	Screw, Cross	8909008	7
16	Moving Disk	8459026 (8459027)	1	38	Screw, Cross	8909044	4
17	Moving Seal Ring	8370137	1	39	Small Gear	8241015	1
18	Shaft	8258047	1	40	Pin	8993003	1
19	Anti-friction Washer	8216011	1	41	Motor	6158026	1
20	O-ring	8378111	2	42	Screw, Cross	8909016	4
21	O-ring	8378195	2				

Numbers in above parentheses are for F79B-LCD, the others are same as F79A-LCD.

Flow Meter Connector & Animated Connector

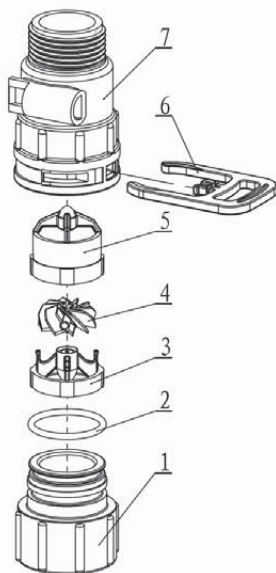

5447018 Flow Meter

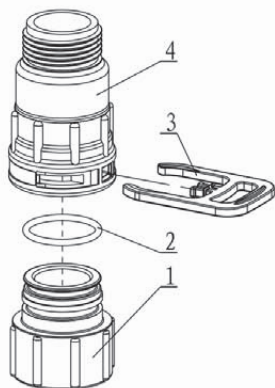

5457002 Animated Connector

5447018 Flow Meter				5457002 Animated Connector			
Item No.	Description	Part No.	Quantity	Item No.	Description	Part No.	Quantity
1	Animated Nut	8945001	1	1	Animated Nut	8945001	1
2	O-ring	8378081	1	2	O-ring	8378081	1
3	Impeller Supporter	5115022	1	3	Clip	8270004	1
4	Impeller	5436010	1	4	Connector	8458038	1
5	Impeller Supporter	5115021	1				
6	Clip	8270004	1				
7	Shell	8002001	1				

F82A-LCD, F82B-LCD Valve Body Assembly

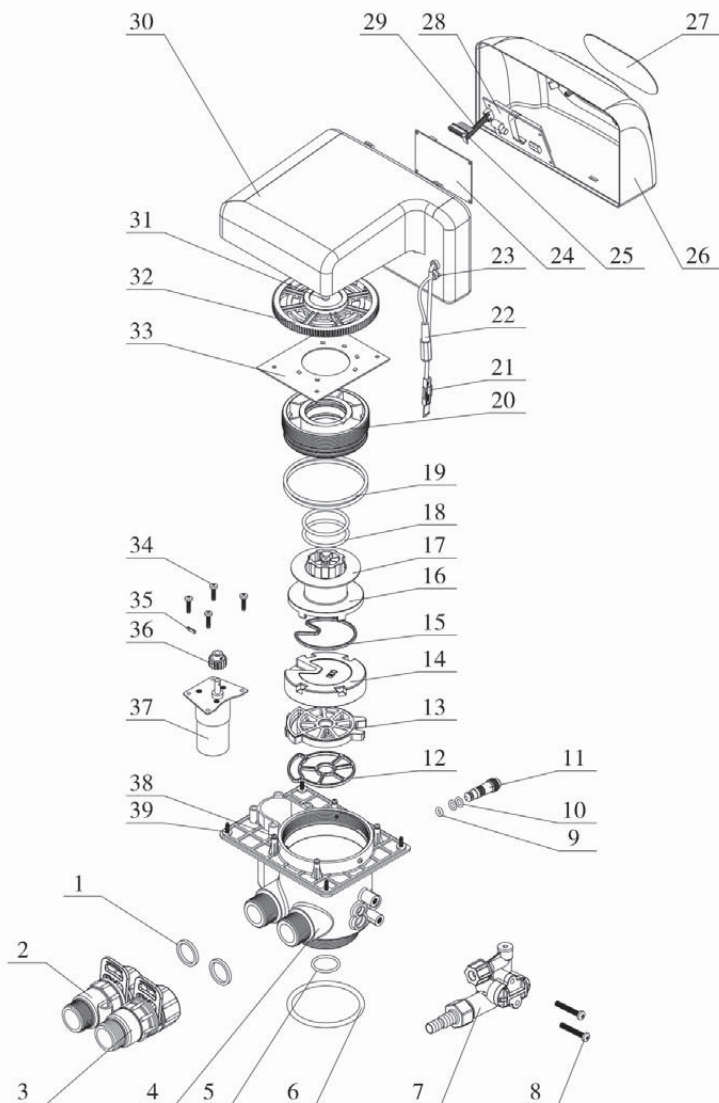

F82A-LCD/ F82B-LCD Valve Body Components

Item No.	Description	Part No.				Quantity
		F82A1	F82A3	F82B1	F82B3	
1	Washer	/	8371001	/	8371001	2
2	Flow Meter	/	5447018	/	5447018	1
3	Animated Connector	/	5457002	/	5457002	1
4	Valve Body	5022030	5022030	5022030	5022030	1
5	O-ring	8378078	8378078	8378078	8378078	1
6	O-ring	8378143	8378143	8378143	8378143	1
7	6300 Injector	5468009	5468009	5468009	5468009	1
	6800 Injector	Selection				
8	Screw, Cross	8902017	8902017	8902017	8902017	2
9	O-ring	8378015	8378015	8378015	8378015	1
10	O-ring	8378004	8378004	8378004	8378004	2
11	Adjusting Screw	8906003	8906003	8906003	8906003	1
12	Seal Ring	8370049	8370049	8370049	8370049	1
13	Fixed Disk	8469026	8469026	8469026	8469026	1
14	Moving Disk	8459029	8459029	8459030	8459030	1
15	Moving Seal Ring	8370138	8370138	8370138	8370138	1
16	Shaft	8258048	8258048	8258048	8258048	1
17	Anti-friction Washer	8216012	8216012	8216012	8216012	1
18	O-ring	8378123	8378123	8378123	8378123	2
19	O-ring	8378102	8378102	8378102	8378102	2
20	Fitting Nut	8092012	8092012	8092012	8092012	1
21	Probe Wire	/	6386022	/	6386022	1
22	Wire for Power	5513003	5513003	5513003	5513003	1
23	Cable Clip	8126004	8126004	8126004	8126004	2
24	Control Board	6382138	6382138	6382138	6382138	1
25	Wire for Locating Board	5511004	5511004	5511004	5511004	1
26	Front Cover	8300017	8300017	8300007	8300007	1

27	Label	8865016	8865016	8865007	8865007	1
28	Display Board	6381006	6381006	6381006	6381006	1
29	Wire for Display Board	5512002	5512002	5512002	5512002	1
30	Dust Cover	8005016	8005016	8005016	8005016	1
31	Screw, Cross	8909013	8909013	8909013	8909013	1
32	Gear	5241011	5241011	5241011	5241011	1
33	Locating Board	6380012	6380012	6380012	6380012	1
34	Screw, Cross	8909044	8909044	8909044	8909044	4
35	Pin	8993003	8993003	8993003	8993003	1
36	Small Gear	8241015	8241015	8241015	8241015	1
37	Motor	6158073	6158073	6158073	6158073	1
38	Screw, Cross	8909008	8909008	8909008	8909008	7
39	Screw, Cross	8909016	8909016	8909016	8909016	4

F82AG-LCD/82604AB/F82BG-LCD/82604BB Valve Body Assembly

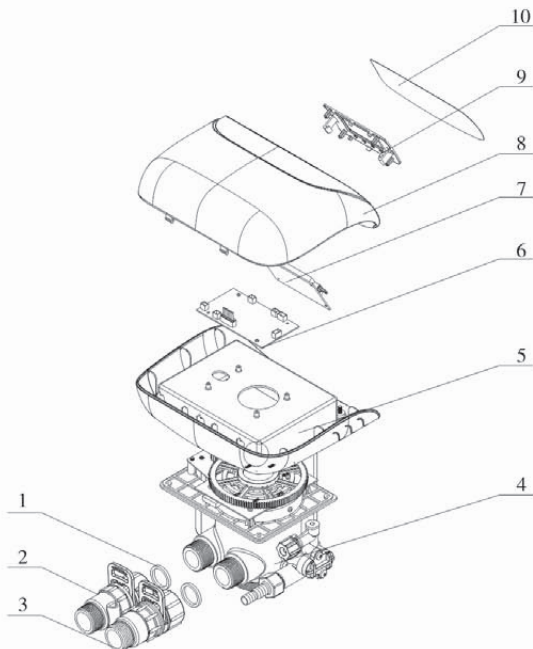

F82AG-LCD/F82BG-LCD Valve Body Components:

Item No.	Description	Part No.				Quantity
		F82AG1-LCD	F82AG3-LCD	F82BG1-LCD	F82BG3-LCD	
1	Washer	/	8371001	/	8371001	2
2	Flow Meter	/	5447018	/	5447018	1
3	Animated Connector	/	5457002	/	5457002	1
4	Valve Body Assembly	Same as F82A1	Same as F82A3	Same as F82B1	Same as F82B3	1
5	Dust Cover	8005019	8005019	8005019	8005019	1
6	Control Board	6382138	6382138	6382138	6382138	1
7	Display Board	6381006	6381006	6381006	6381006	1
8	Front Cover	5300001	5300001	5300001	5300001	1
9	Toggle	8109027	8109027	8109027	8109027	1
10	Label	8865020	8865020	8865020	8865020	1

Structure Chart of New Injector:

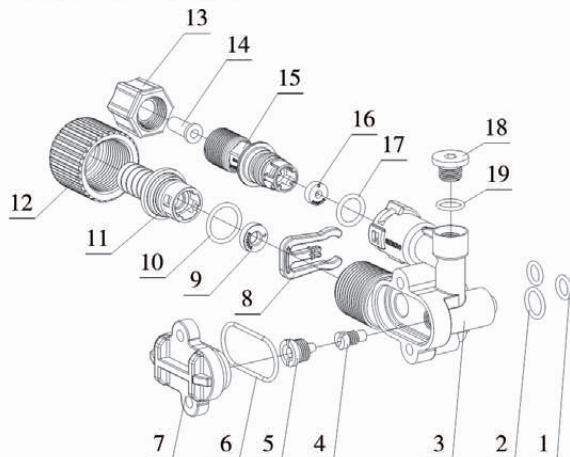

New Injector (6800 seires) Components:

Item No.	Description	Part No.	Quantity	Item No.	Description	Part No.	Quantity
1	O-ring 7.5×1.8	8378016	2	11	Connector	8458064	1
2	O-ring 10.82×1.78	8378012	1	12	Animated Nut	8945025	1
3	Injector Body	8008010	1	13	Nut Nex. Hd	8940001	1
4	Throat	Optional	1	14	Tube	8457004	1
5	Nozzle	Optional	1	15	Connector	8458068	1
6	O-ring 30×1.8	8378025	1	16	BLFC	Optional	1
7	Injector Cover	8315001	1	17	O-ring 11×2	8378169	1
8	Clip	8270010	1	18	Plug	8323002	1
9	DLFC	Optional	1	19	Seal Ring	8370003	1
10	O-ring 15×1.8	8378179	1				

Structure Chart of Old Injector:

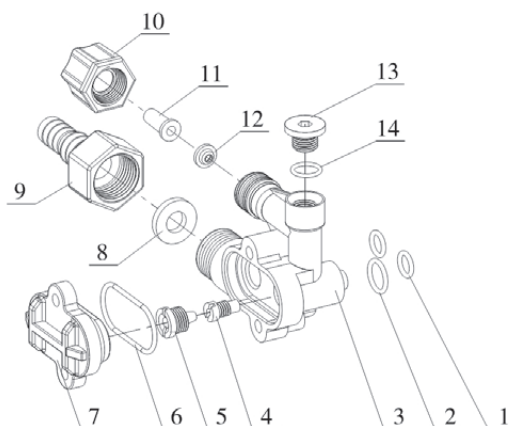

Old Injector (6300 series) Components:

Item No.	Description	Part No.	Quantity	Note	Item No.	Description	Part No.	Quantity	Note
1	O-ring 7.5×1.8	8378016	2		8	DLFC	8468005	1	F79
							8468007		F82
2	O-ring 10.82×1.78	8378012	1		9	Connector	8458017	1	
3	Injector Body	8008001	1		10	Nut Nex. Hd	8940001	1	
4	Throat	8467005	1	F79	11	Tube	8457004	1	
		F82							
5	Nozzle	8454005	1	F79	12	BLFC	8468002		
				F82					
6	O-ring 30×1.8	8378025	1		13	Plug	8323002	1	
7	Injector Cover	8315001	1		14	Seal Ring	8370003	1	

4. Warranty Card

Dear client:

This warranty card is the guarantee proof of Runxin brand multi-functional flow control valve. It is kept by client self. You could get the after-sales services from the supplier which is appointed by Runxin manufacturer. Please keep it properly. It couldn't be retrieved if lost. It couldn't be repaired free of charge under the below conditions:

1. Guarantee period expired. (One year)
2. Damage resulting from using, maintenance, and keeping that are not in accordance with the instruction.
3. Damage resulting from repairing not by the appointed maintenance personnel.
4. Content in guarantee proof is unconfirmed with the label on the real good or be altered.
5. Damage resulting from force majeure.

Product Name	 Multi-functional Flow Control Valve for Water Treatment Systems
Model	Code of Valve Body
Purchase Company Name	Tel/Cel.
Problem	
Solution	
Date of Repairing	Date of Accomplishment
	Maintenance Man Signature

When product needs warranty service, please contact with your direct supplier firstly, after got permission, then fill in the below content and send this card together with the product to the appointed suppliers or Runxin company.

End-user Company Name		Tel/Cel.	
Purchase Company Name		Tel/Cel.	
Model	Code of Valve Body		
Tank size $\phi \times$	Resin Volume L	Raw Water Hardness mmol/L	
Water Source: Ground-water <input type="checkbox"/> Tap Water <input type="checkbox"/>	Water Treatment Capacity m^3	Backwash Time min	
Brine & Slow Rinse Time min	Brine Refill Time min	Fast Rinse Time min	
Problem Description			



WENZHOU RUNXIN MANUFACTURING MACHINE CO.,LTD

ADD: NO.169, RUNXIN ROAD, SHANFU TOWN, WENZHOU, ZHEJIANG, CHINA.

TEL.:0086-577-88630038, 88576512, 85956057 FAX:0086-577-88633258

E-MAIL: sales@run-xin.com <http://www.run-xin.com>