



## Multi-functional Flow Control Valve for Water Treatment Systems

- 53602 ( Old Model No.: F71B3 )
- 53604 ( Old Model No.: F67C3 )
- 53604S ( Old Model No.: F67B3 )
- 53606S ( Old Model No.: F67B3-A )
- 53610 ( Old Model No.: N75A3 )
- 53610B ( Old Model No.: N75B3 )

### User Manual



Please read this manual in details  
before using the valve and keep it properly  
in order to consult in the future

0WRX.466.597

**MODEL: F71B3/F67C3/F67B3/F67B3-A/N75A3/N75B3**

Before the valve put into use, please fill in the below content so as to help us to refer in the future.

## Filter System Configuration

Tank Size: Dia. \_\_\_\_\_ mm, Height \_\_\_\_\_ mm;

Refilled Filter Materials \_\_\_\_\_ Kg; Granularity of Filter Materials \_\_\_\_\_ mm;

Control Valve Model \_\_\_\_\_ ; Number \_\_\_\_\_ ;

Pressure of Inlet Water \_\_\_\_\_ Mpa; Turbidity of Inlet Water \_\_\_\_\_ NTU;

Water Source: Ground-water ; Filtered Ground-water ;

Tap Water ; Other \_\_\_\_\_.

## Parameter Set

Parameter	Unit	Factory Default	Actual Value
Time of Day	h:min	Random	
Control Mode	/	A-01	
Rinsing Time	h.:min.	02:00	
Water Treatment Capacity	m <sup>3</sup>	F67/F71: 10.00m <sup>3</sup> N75: 80.00m <sup>3</sup>	
Unit Mode	/	HU-01(m <sup>3</sup> )	
Rinsing Frequency	/	F-00	
Backwash Time	min.:sec.	10:00	
Fast Rinse Time	min.:sec.	10:00	
Closing Time of Drainage Ball Valve	h.:min.	01:00	
Opening Time of Drainage Ball Valve	min.:sec.	00:30	
Maximum Interval Rinsing Days	D.	30	

## Catalogue

Notice .....	1
1. Product Overview .....	2
1.1. Main Application & Applicability .....	2
1.2. Product Characteristics .....	2
1.3. Service Condition .....	3
1.4. Product Structure and Technical Parameters .....	3
1.5. Installation .....	5
2. Basic Setting & Usage .....	9
2.1. The Function of PC Board .....	9
2.2. Basic Setting & Usage .....	10
3. Applications .....	12
3.1. Filter Flow Chart .....	12
3.2. The Function and Connection of PC Board .....	12
3.3. System Configuration and Flow Rate Curve .....	14
3.4. Parameter Enquiry and Setting .....	16
3.5. Trial Running .....	19
3.6. Trouble-Shooting .....	19
3.7. Assembly & Parts .....	21
4. Warranty Card .....	31

## Notice

- To ensure normal operation of the valve, please consult with professional installation or repairing personnel before use it.
- If there are any of pipeline engineering and electric works, there must be finished by professional at the time of installation
- Do not use the control valve with the water that is unsafe or unknown quality.
- Depending on the changing of working environment and water requirement, each parameter of filter should be adjusted accordingly.
- Test water periodically to verify that system is performing satisfactorily.
- Do not put the valve near the hot resource, high humidity, corrosive, intense magnetic field or intense vibrations environment. And do not leave it outside.
- Forbidden to use the drain pipeline or other connectors as support to carry the system.
- Please use this product under the water temperature between 5~50°C, water pressure 0.15~0.6MPa. Failure to use this product under such conditions voids the warranty.
- If the water pressure exceeds 0.6Mpa, a pressure reducing valve must be installed before the water inlet. While, if the water pressure under 0.15MPa, a booster pump must be installed before the water inlet.
- It is suggested to install PPR pipe, corrugated pipe or UPVC pipe, instead of TTLSG pipe.
- Do not let children touch or play, because carelessness operating may cause the procedure changed.
- When the attached cables of this product and transformer are changed, they must be changed to the one that is from our factory.
- For 53610 (N75A3) product, in order to disassemble easily, it is suggested to install the strainer with M88×2 male thread.

## 1. Product Overview

### 1.1. Main Application & Applicability

Used for filtering water treatment systems

Be suitable for

Swimming pool filtering equipment

Carbon filter or sand filter in RO pretreatment filtering system

Iron and manganese removal system

### 1.2. Product Characteristics

#### ● Simple structure and reliable sealing

It adopts hermetic head faces with high degree pottery and corrosion resistance for opening and closing. It combines with Service, Backwash, and Fast Rinse.

#### ● No water pass the valve in rinsing in single tank type

#### ● Manual function

Realize rinsing immediately by pressing “” at any time.



#### ● Long outage indicator

If outage overrides 3 days, the time of day indicator “12:12” will flash to remind people to reset new time of day. The other set parameters do not need to reset. The process will continue to work after power on.

#### ● LED dynamic screen display

The stripe on dynamic screen flash, it indicates the control valve is in service; otherwise, it is in rinsing cycle.

#### ● Buttons lock

No operations to buttons on the controller within 1 minute, button lock indicator light on which represent buttons are locked. Before operation, press and hold the “” and “” buttons for 5 seconds to unlock. This function can avoid incorrect operation.

#### ● Rinsing frequency

It could set up multiple rinsing times, which means several times of backwash and fast rinse but one time of service. It is much better for cleaning the filter materials.

#### ● All parameters can be modified

According to the water quality and usage, the parameters can be adjusted.

#### ● It can choose meter type or time clock type

#### ● Remote handling input

This connector can receive external signal, used together with PLC, and computer etc. to control the valve.

● **Interlock function**

It has a function of interlock to realize only one valve in rinsing, but the other valves are in service while there are several valves parallel in system. In multi-steps treatment systems such as RO pre-treatment, when several valves are in series, there is only one valve in rinsing to ensure pass water all the times while different valves in rinsing.

**1.3. Service Condition**

Filter Valve should be used under the below conditions:

Items		Requirement
Working conditions	Water pressure	0.15MPa ~ 0.6MPa
	Water temperature	5°C ~ 50°C
Working environment	Environment temperature	5°C ~ 50°C
	Relative humidity	≤95% ( 25°C )
	Electrical facility	AC100 ~ 240V/50 ~ 60Hz
Inlet water quality	Water turbidity	< 20FTU

- When the water turbidity exceeds the conditions, the impurity in the inlet water should be coagulated and precipitated firstly.

**1.4. Product Structure and Technical Parameters**

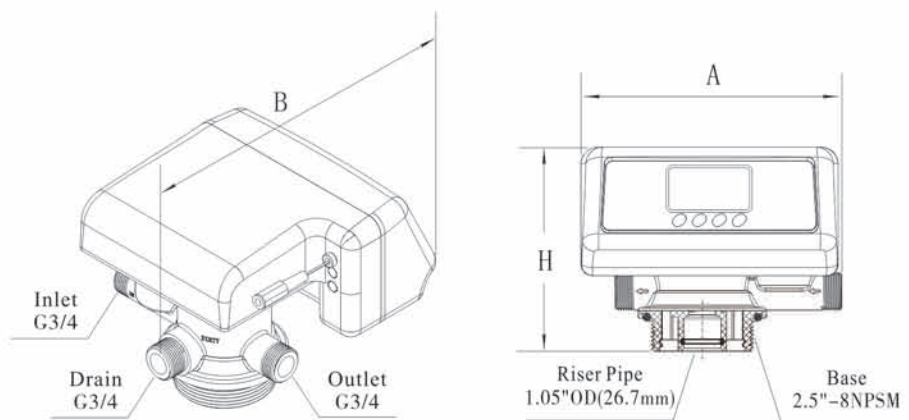

Model	A(mm) max	B(mm) max	H(mm) max	Transformer Output	Flow Rate m <sup>3</sup> /h @0.3MPa
F71B3 ( 53602 )	182.5	195.5	143	DC12V, 1.5A	2.0

**F67B3 Appearance:**

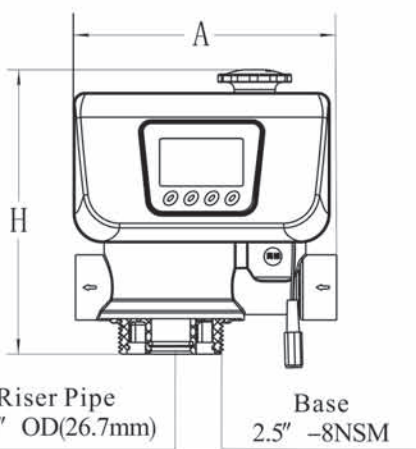
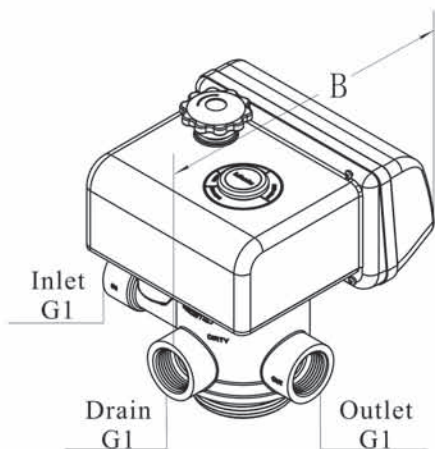

**F67C3 Appearance:**

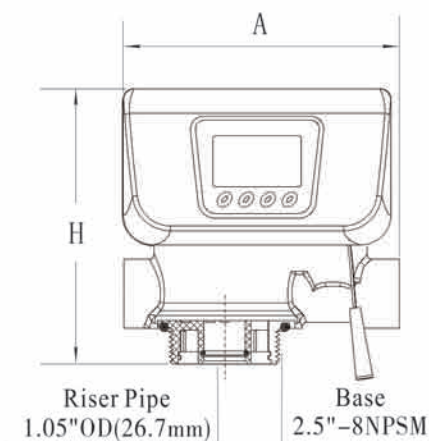
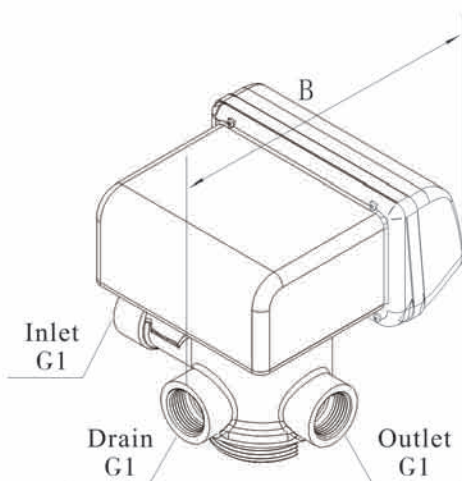

Model	A(mm) max	B(mm) max	H(mm) max	Riser Pipe Size	Transformer Output	Flow Rate m <sup>3</sup> /h @0.3MPa
F67B3 (53604S)	180	194	190	1.05" OD (26.7mm)	DC12V, 1.5A	4.0
F67B3-A (53606S)				1" D-GB (32mm)		
F67C3 (53604)	180	194	178.5	1.05" OD (26.7mm)		

**N75A3 Appearance:**

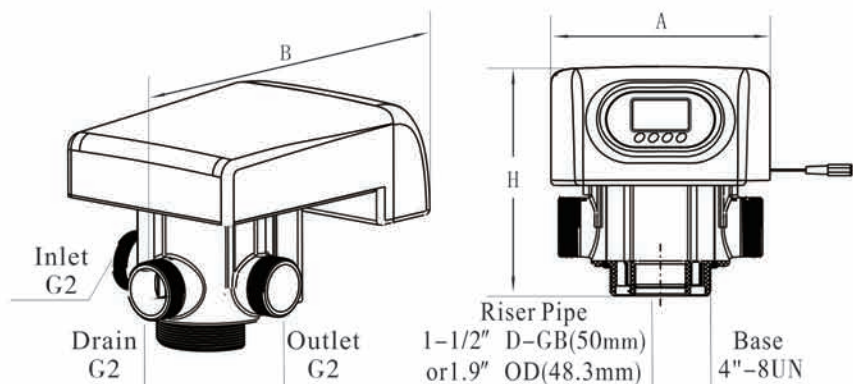

Model	A(mm) max	B(mm) max	H(mm) max	Transformer Output	Flow Rate m <sup>3</sup> /h @0.3MPa
N75A3 (53610)	220	346.5	230.5	DC24V, 1.5A	10.0
N75B3 (53610B)	216.5	252	312.5		

**Flow meter appearance:**

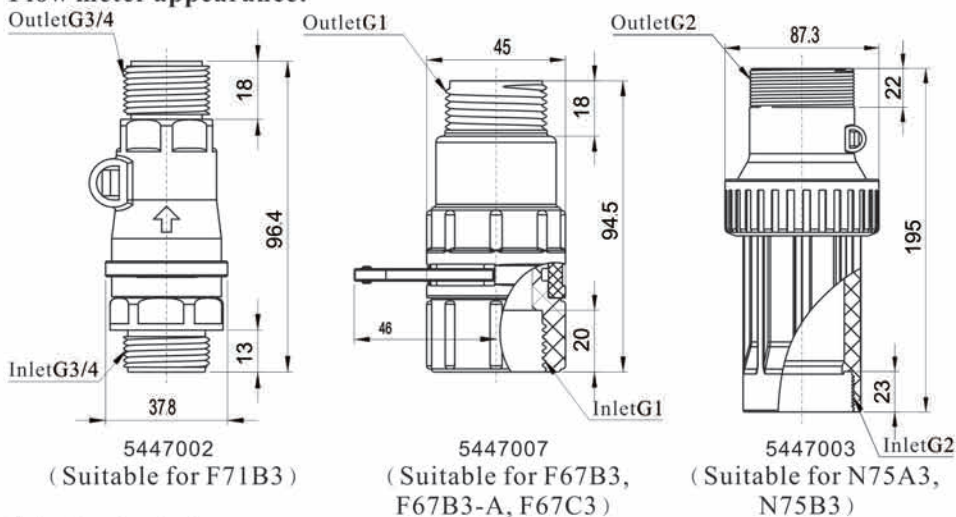

**1.5. Installation**

**A. Installation notice**

Before installation, read all those instructions completely. Then obtain all materials and tools needed for installation.

The installation of product, pipes and circuits should be accomplished by professional



to ensure the product can operate normally.

Perform installation according to the relative pipeline regulations and the specification of Water Inlet, Water Outlet, and Drain Outlet.

**B. Device location**

- ① The filter should be located closely to drain.
- ② Ensure the unit is installed in enough space for operating and maintenance.
- ③ The unit should be kept away the heater, and exposed outdoor. Sunshine or rain will cause the system damage.
- ④ Please avoid to install the system in one Acid/Alkaline, Magnetic or strong vibration circumstance, because above factors will cause the system disorder.
- ⑤ Do not install the filter, drain pipeline in circumstance which temperature may drop below 5℃, or above 50℃.
- ⑥ One place is recommended to install the system which causes the minimum loss in case of water leaking.

**C. Pipeline connection (Taking N75A3 for example)**

① Install control valve

a. As the figure 1-1 shows, select the relevant riser pipe, glue the riser pipe to the bottom strainer and put it into the mineral tank, cut off the exceeding tube out of tank top opening. Plug the riser tube in case of mineral entering.

b. Fill the mineral to the tank, and the height is accordance with the design code.

c. Remove the tap covering on the central tube and check if the riser tube is on the central of tank.

d. Install the top distributor to the valve and insert the riser tube into control valve and screw tight control valve.

**Note:**

- The length of riser tube should be neither higher 2mm nor lower 5mm tank top opening height, and its top end should be rounded to avoid damage of O-ring inside the valve.
- Avoid floccules substance together with filter materials fill in the tank.
- Avoid O-ring inside control valve falling out while rotating it on the tank

② Install flow meter

As figure 1-2 shows, put the sealing gasket in the flow meter fittings, screw in the

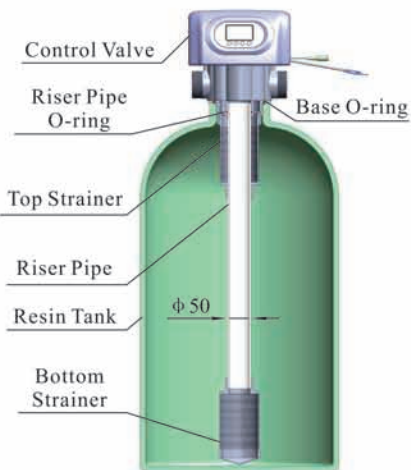

**Figure 1-1**

outlet of the valve, and insert the probe wire to flow meter.

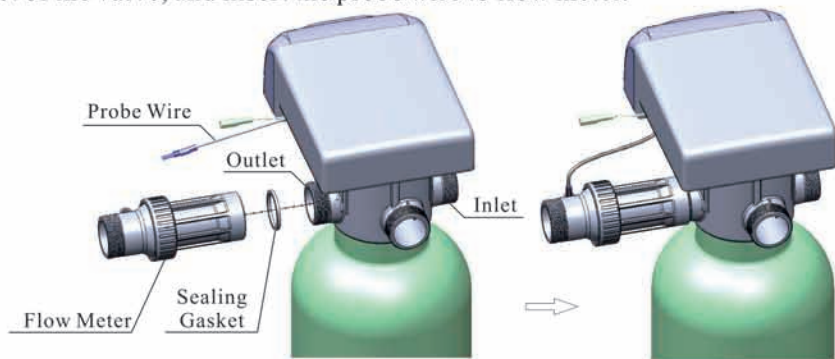

Figure1-2

### ③ Pipeline connection

- As figure 1-3 shows, install a pressure gauge in water inlet.
- Install valve A, valve B, valve C and valve D in the inlet and outlet pipeline. The valve D is sampling valve.
- Install the check valve in the outlet pipeline.
- Inlet pipeline should be in parallel with outlet pipeline. Support inlet and outlet pipeline with fixed holder.

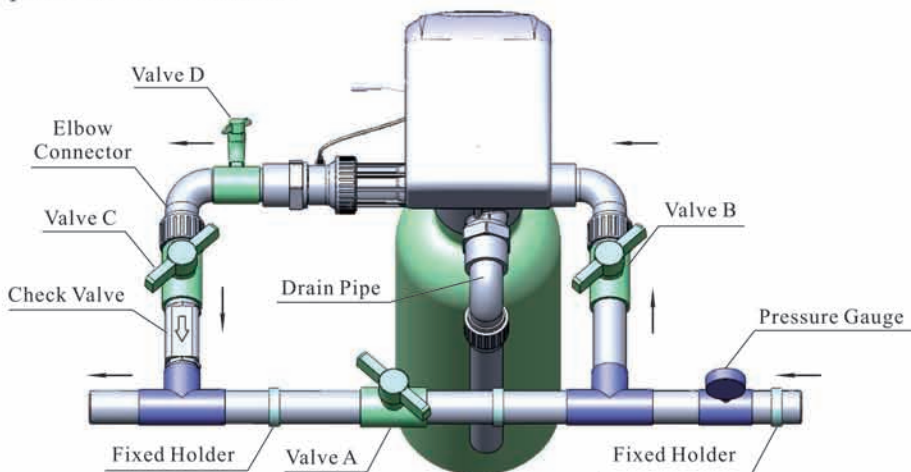

Figure 1-3

### Note:

- If making a soldered copper installation, do all sweat soldering before connecting pipes to the valve. Torch heat will damage plastic parts.
- When turning threaded pipe fittings onto a plastic fitting, use care not to cross thread or broken valve.

④ Install drain pipeline

Directly connect the drain with the rigid pipeline, such as UPVC, etc.

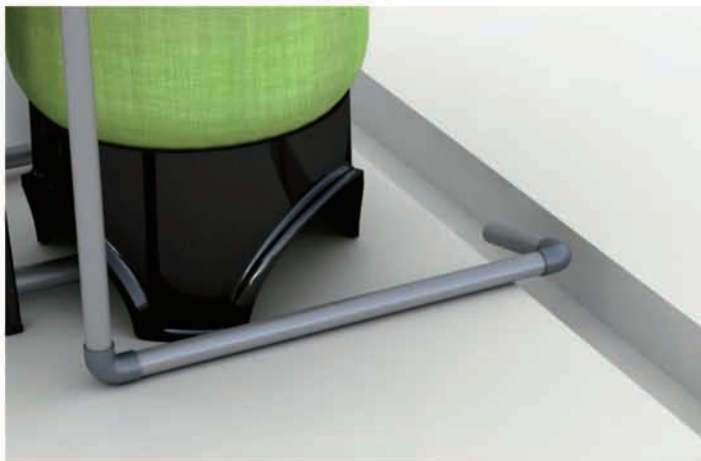

Figure 1-4

**Note:**

- Control valve should be higher than drain outlet, and be better not far from the drain hose.
- Be sure not connect drain with sewer, and leave a certain space between them (As the figure 1-4 shows), avoid waste water be absorbing to the water treatment equipment.
- If waste water is used for other purpose, please use another container for loading. And also keep a certain space between drain and container.

## 2. Basic Setting & Usage

### 2.1. The Function of PC Board

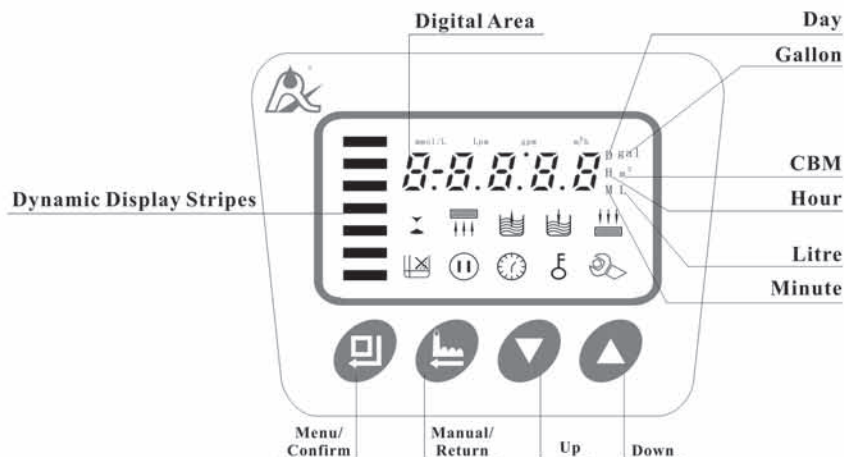

A. “🕒” Time of day indicator

“🕒” light on, display the time of day.

B. “🔒” Button lock indicator

● “🔒” Light on, indicate the buttons are locked. At this moment, press any single button will not work (No operation in one minute, “🔒” will light on and lock the buttons.)

● Solution: Press and hold both “▲” and “▼” for 5 seconds until the “🔒” light off.

C. “🌀” Program mode indicator

● “🌀” Light on, enter program display mode. Use “▲” or “▼” to view all values.

● “🌀” Flash, enter program set mode. Press “▲” or “▼” to adjust values.

D. “☑️” Menu/Confirm button

● Press “☑️”, “🌀” light on, enter program display mode and use “▲” or “▼” to view all values.

● In program display mode, press “☑️”, “🌀” flash, enter program set mode, press “▲” or “▼” and adjust values.

● Press “☑️” after all parameters are set, and then the voice “Di” means all setting are success and return program display mode.

E. “⏪” Manual/Return button

● Press “⏪” in working conditions, it can proceed to next step. (Example: when the outlet water fails to reach the requirement, you can press “⏪” to end the

service and start an immediate rising. During the process of rising, pressing the “⏪” button can end one step in advance and proceed to the next step.)

● Press “⏪” in program display mode, and it will return in Service; Press “⏪” in program set mode, and it will return program display mode.

● Press “⏪” while adjusting the value, then it will return program display mode directly without saving value.

F.Down “⏴” and Up “⏵”





● In program display mode, press “⏴” or “⏵” to view all values.

● In program set mode, press “⏴” or “⏵” to adjust values.







● Press and hold both “⏴” and “⏵” for 5 seconds to lift the Button Lock status.

## 2.2. Basic Setting & Usage

A. Parameter specification(Taking F67C3 for example)

Function	Indicator	Factory Default	Parameter Set Range	Instruction
Time of Day		Random	00:00~23:59	Set the time of day when use; “:” flash.
Control Mode	A-01	A-01	A-01	A-01: Rinse on the day although the available volume of treated water drops to zero (0). Rinsing starts at the rinsing time.
			A-02	A-02: Rinse immediately when the available volume of treated water drops to zero (0).
Rinsing Time	02:00	02:00	00:00~23:59	Rinsing Time; “:” light on
Water Treatment Capacity		10m <sup>3</sup>	0~99:59	
Unit Mode	HU-01	m <sup>3</sup>	HU-01~03	HU-01 is m <sup>3</sup> ;HU-02 is gal; HU-03 is L.
Rinsing Frequency	F-00	00	0~20	Rinsing frequency. For example, F-01 indicates service 1 time, backwash and fast rinse 2 times;
Backwash Time		10:00	0~99:59	Backwash time(Minute), correct to second;
Fast Rinse Time		10:00	0~99:59	Fast Rinse Time(Minute), correct to second;
Closing Time of Drainage Ball Valve	C-01:00	1H	00:01~99:59	The closing time of drainage ball valve is H:min.
Opening Time of Drainage Ball Valve	0-00:30	30sec.	00:10~99:59	The opening time of drainage ball valve is Min: sec.
Maximum Interval Rinsing Days	H-30	30D.	0~40	Set to 0 days is invalid
Enquiry Rinsing Times		/		

B. Process Display (Taking meter type for example)

Working status	The circular interface displays in turn		
Service			
Backwash			
Fast Rinse			

**Illustration:**

- During the rinsing process, like under backwash and fast rinse status, the display screen will circularly shows: ① Current status (Such as 2-10:00min:sec etc.), ② Time of day.
- The display screen will only show “-00-” when the electrical motor is running.
- The time of day figure “🕒” flash continuously, such as “12:12” flash, indicates long outage of power. It reminds to reset the time of day.
- The display will show the error code, such as “-E1-” when the system is in error.
- Working process: Service→ Backwash→ Fast Rinse.

### 3. Applications

#### 3.1. Filter Flow Chart

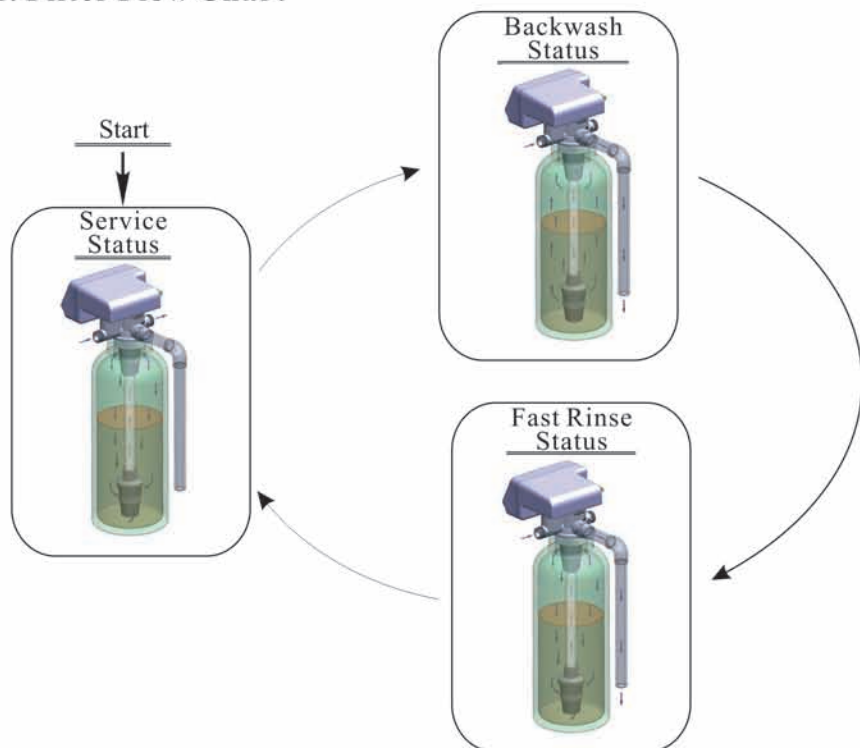

#### 3.2. The Function and Connection of PC Board

A. F67/F71 control board (As below Figure 3-1A shows)

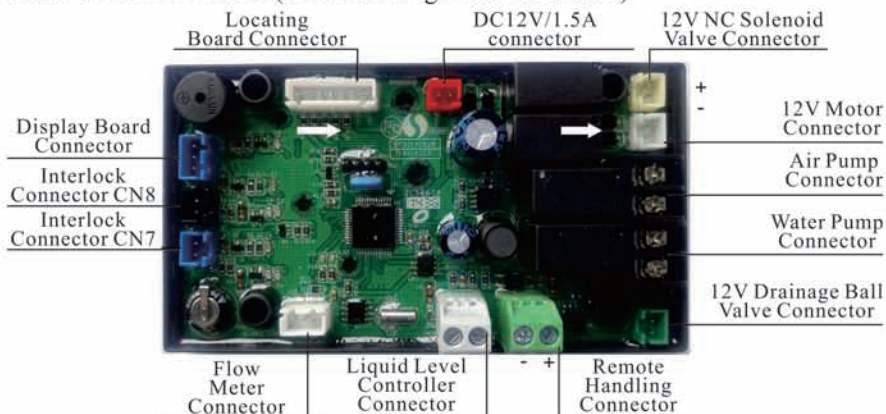

Figure3-1A

N75 control board (As below Figure 3-1B shows)

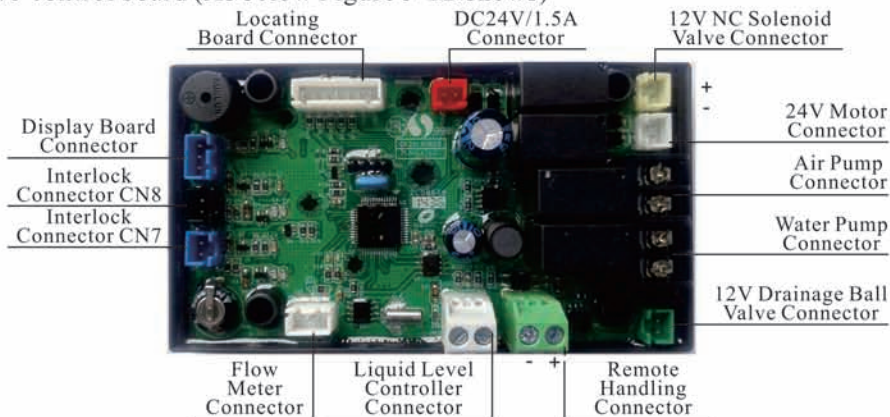

Figure3-1B

B. The wiring of liquid level controller connector, it refers to Figure3-2:

C. The wiring of remote handling connector, it refers to Figure3-3:



Liquid Level Controller  
Figure3-2



External GND DC5-24V  
Figure3-3

D. If the working current is less than 5A, the wiring of air pump, it refers to Figure 3-4 (Be suitable for iron and manganese removal device).

E. If the working current is less than 5A, the wiring of water pump, it refers to Figure 3-5 (Be suitable for iron and manganese removal device).

F. If the working current is more than 5A, the wiring of air pump, it refers to Figure 3-6 (Be suitable for iron and manganese removal device).

G. If the working current is more than 5A, the wiring of water pump, it refers to Figure 3-7 (Be suitable for iron and manganese removal device).



Figure3-4



Figure3-5

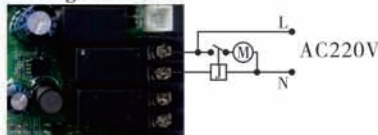

Figure3-6

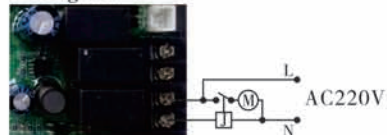
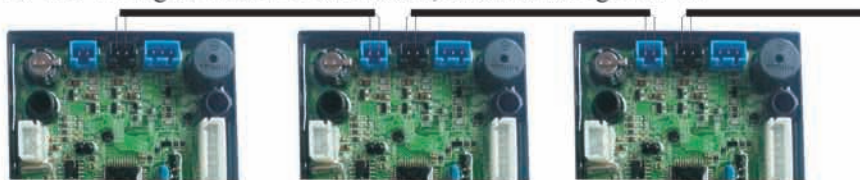

Figure3-7



H. The wiring of interlock connector, it refers to Figure 3-8:



When connect the interlock cable with the main board socket, the cable color should be the same as the socket color.

Figure3-8

### 3.3. System Configuration and Flow Rate Curve

#### A. Product Configuration

Product configuration with tank, filter materials volume

Tank Size	Volume of Filter Material	Carbon Filter		Sand Filter	
		Filtering Flow Rate	Backwash Flow Rate	Filtering Flow Rate	Backwash Flow Rate
mm	L	m <sup>3</sup> /h	m <sup>3</sup> /h	m <sup>3</sup> /h	m <sup>3</sup> /h
φ180×1130	16	0.3	0.9	0.6	1.3
φ205×1300	25	0.4	1.1	0.8	1.7
φ255×1390	40	0.6	1.7	1.2	2.6
φ300×1390	60	0.8	2.5	1.7	3.8
φ355×1670	100	1.2	3.4	2.4	5.2
φ400×1670	120	1.5	4.5	3.1	6.8
φ450×1670	150	2	5.9	4.1	8.8
φ500×1800	200	2.4	7	4.9	10.6
φ600×1800	300	3.4	10	7	15.2

Attention: the filtering flow rate of carbon filter is calculated based on the 12m/h operation rate; the backwash flow rate is calculated based on the 10L/(m<sup>2</sup>\*s) backwash intensity; the filtering flow rate of sand filter is calculated based on the 25m/h operation rate; the backwash flow rate is calculated based on the 15L/(m<sup>2</sup>\*s) backwash intensity.

B. Flow Rate Characteristic

1). Pressure-flow rate curve

F71:

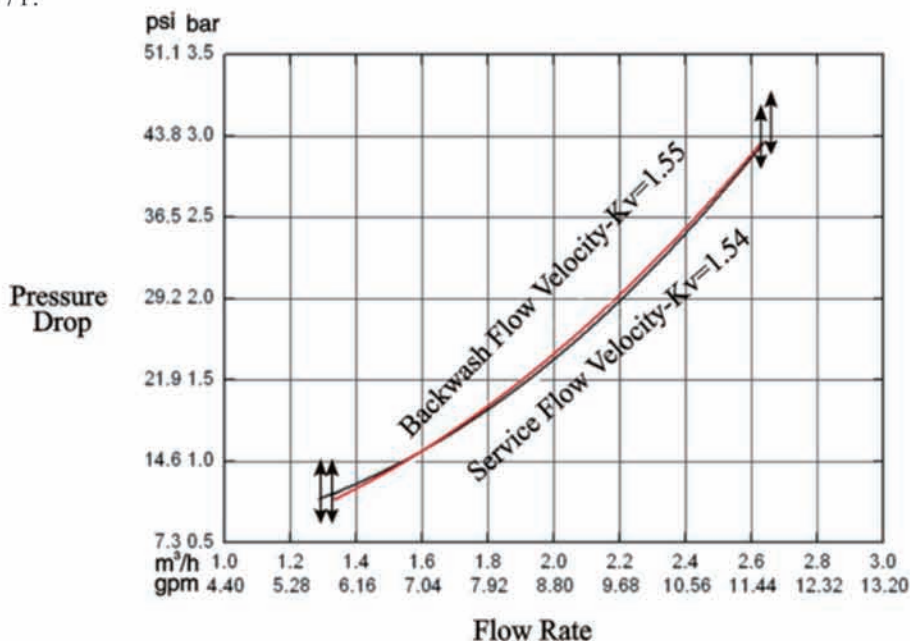

F67:

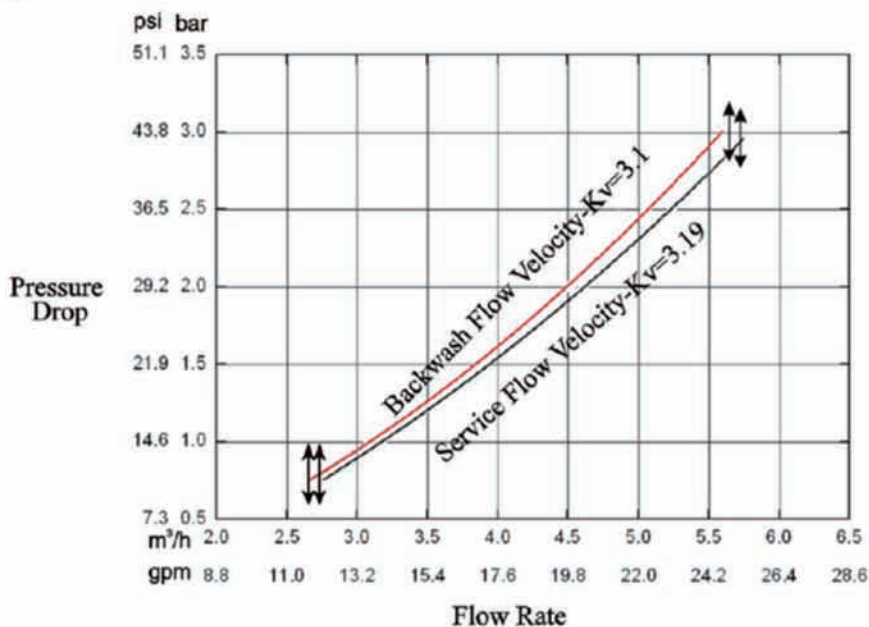

N75:

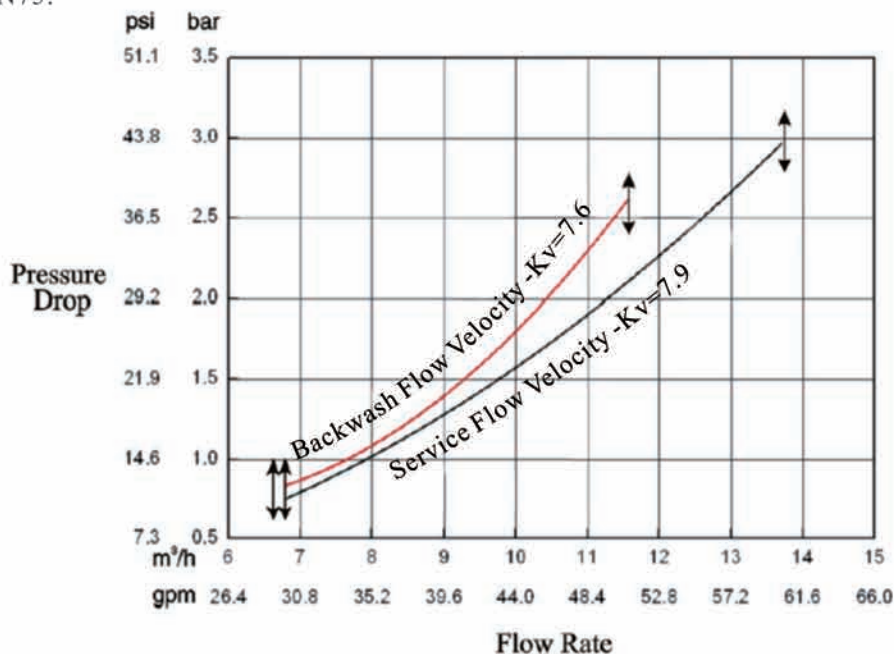

### 3.4. Parameter Enquiry and Setting

#### 3.4.1. Parameter Enquiry



When “ ⚙ ” light on, press and hold both “ ▲ ” and “ ▼ ” for 5 seconds to lift the button lock status; then press “ ⏏ ” and “ ⚙ ” light on, enter into program display mode; press “ ▲ ” or “ ▼ ” to view each value according to below process. (Press “ ⏏ ” to exit from enquiry status). Taking F67C3 for example :



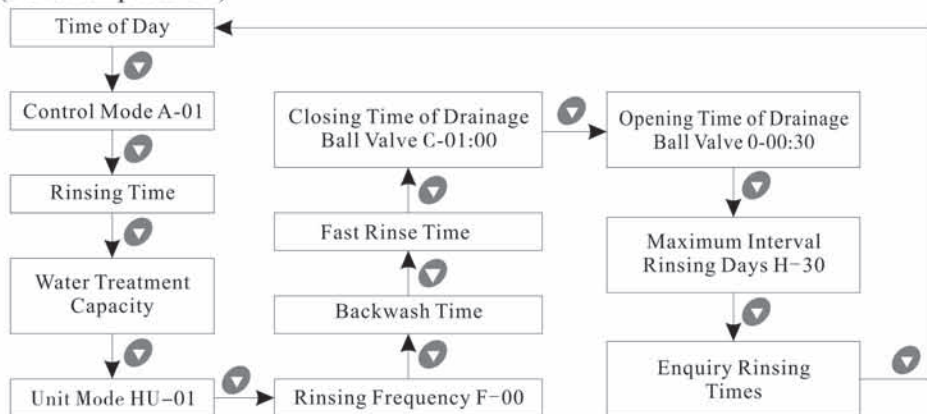



























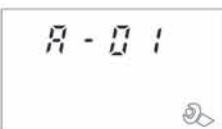









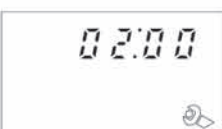







F67C3:











(For example A-01)

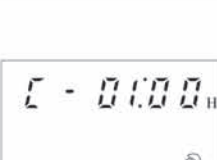

3.4.2 Parameter Setting (Taking F67C3/F71B3 for example).

In program display mode, press “” and enter into program set mode. Press “” or “” to adjust the value.

Items	Process steps	Symbol
Time of Day	<p>When the clock symbol “” continuously flash, it reminds to reset:</p> <ol style="list-style-type: none"> <li>1. Press “” to enter into program display mode; both “” and “” symbol light on, “:” flash;</li> <li>2. Press “”, both “” and hour value flash, through “” or “” to adjust the hour value;</li> <li>3. Press “” again, both “” and minute value flash, through “” or “” to adjust the minute value;</li> <li>4. Press “” and hear a sound “Di”, then finish adjustment, press “” to turn back.</li> </ol>	
Control Mode	<ol style="list-style-type: none"> <li>1. In control mode display status, press “” and enter into program set mode, “” and 01 value flash;</li> <li>2. Press “” or “”, set the value to be A-01 or A-02 control mode;</li> <li>3. Press “” and hear a sound “Di”, then finish adjustment, press “” to turn back.</li> </ol>	
Rising Time	<ol style="list-style-type: none"> <li>1. In the rising time program display mode, press “” and enter into program set mode, “” and 02 value flash; through “” or “” to adjust the hour value;</li> <li>2. Press again, both “” and “00” flash, through “” or “” to adjust the minute value;</li> <li>3. Press “” and hear a sound “Di”, then finish adjustment, press “” to turn back.</li> </ol>	
Water Treatment Capacity	<ol style="list-style-type: none"> <li>1. In the water treatment capacity program display mode, press “” and enter into program set mode, “” and 10 value flash;</li> <li>2. Press “” or “” to set the integer value of water treatment capacity;</li> <li>3. Press “”, the decimal value of water treatment capacity flash, press “” or “” to set the value;</li> <li>4. Press “” and hear a sound “Di”, then finish adjustment, press “” to turn back.</li> </ol>	
Unit Mode	<ol style="list-style-type: none"> <li>1. In the unit mode display status, press “” and enter into program set mode, “” and 01 value flash;</li> <li>2. Press “” or “” to choose the water unit among m³/gal/L;</li> <li>3. Press “”, and hear a sound “Di”, then finish adjustment, press “” to turn back.</li> </ol>	

<p><b>Rinsing Frequency</b></p>	<p>1. In the rinsing frequency display mode, it shows “F-00”; press “  </p>
<p><b>Backwash Time</b></p>	<p>1. In the backwash time display mode, it shows “  </p>
<p><b>Fast Rinse Time</b></p>	<p>1. In the fast rinse time display mode, it shows “  </p>
<p><b>Closing Time of Drainage Ball Valve</b></p>	<p>1. In the closing time display mode, it shows C-01:00, press “  </p>
<p><b>Opening Time of Drainage Ball Valve</b></p>	<p>1. In the closing time display mode, it shows C-00:30, press “  </p>
<p><b>Maximum Interval Rinsing Days</b></p>	<p>1. In the maximum interval rinsing days display mode, it shows “H-30”, press “  </p>

### 3.5. Trial running

After installing the multi-functional flow control valve on the tank with the connected pipes, as well as setting up the relevant parameters, please conduct the trial running as follows:







- A. Close the inlet valve B & C, and open the bypass valve A. After cleaning the foreign materials in the pipe, close the bypass valve A. (As Figure 1-3 shows)
- B. Press “” and go in the Backwash position; when “” light on, slowly open the inlet valve B to 1/4 position, making the water flow into the resin tank; you can hear the sound of air-out from the drain pipeline. After all air is out of pipeline, then open inlet valve B completely and clean the foreign materials in the tank until the outlet water is clean. It will take 8~10 minutes to finish the whole process.
- C. Press “”, turning the position from Backwash to Fast Rinse; “” light on and start to fast rinse. It will take 10~15 minutes to finish the whole process.
- D. After finishing fast rinse, take out some outlet water for testing: if the water reaches the requirement, press “” to finish the fast rinse; Then the control valve return to Service Status; “” light on and start to running.

Illustration:

In the process of rinsing, the program will be finished automatically in accordance with the setting time; pressing the “” button can end one step in advance and proceed to the next step.

Note:

- If water inflow too fast, the media in tank will be damaged. When water inflow slowly, there is a sound of air emptying from drain pipeline.
- After changing the filter materials, please empty air in the materials according to the above Step B.
- In the process of trial running, please check the water situation in all position, ensuring there is no filter materials leakage.
- The time for Backwash and Fast Rinse position can be set and executed according to the suggestions from the control valve suppliers.

### 3.6. Trouble-Shooting

#### A. Control Valve Fault

Problem	Cause	Correction
<b>1.Filter fails to rinse.</b>	A. Electrical service to unit has been interrupted. B. Rinse time is set incorrect. C. Controller damaged.	A. Assure permanent electrical service (Check fuse, plug, pull chain or switch). B. Reset the time. C. Check or replace the controller.

<b>2. Filter supply raw water.</b>	A. Bypass valve is open. B. Riser pipe leak. C. Interval valve leak.	A. Close the bypass valve. B. Make sure riser pipe and O-ring are not cracked. C. Check or change valve body.
<b>3. Water pressure lost.</b>	A. Iron is in the water supply pipe. B. Iron mass is in the filter.	A. Clean the water supply pipe. B. Clean valve and add filter materials cleaning chemical, increase frequency of rinsing.
<b>4. Loss of filter materials through drain line.</b>	A. Air in the water system. B. The strength of backwash is too high. C. Strainer is broken.	A. Assure that well system is dry and has proper air eliminator control. B. Reduce the strength of backwash. C. Replace the strainer.
<b>5. Control cycle continuously.</b>	A. Locating signal wiring breakdown. B. Controller damaged. C. Foreign material stuck the driving gear.	A. Check and connect locating signal wiring. B. Replace controller. C. Take out foreign material.
<b>6. Drain flows continuously.</b>	A. Internal valve leak. B. When electricity fails to supply, the valve is in backwash or fast rinse position.	A. Check and repair valve body or replace it. B. Turn off bypass valve and restart when power on.

**B. Controller Fault**

<b>Problem</b>	<b>Cause</b>	<b>Correction</b>
<b>1. All indicators display on front panel.</b>	A. Wiring of display board with control board damaged. B. Control board damaged. C. Transformer damaged. D. Electrical service not stable.	A. Check and replace the wiring. B. Replace control board. C. Check and replace transformer. D. Check and adjust electrical service.
<b>2. No display on front panel.</b>	A. Wiring of display board with control board damaged. B. Display board damaged. C. Control board damaged. D. Electricity is interrupted.	A. Check and replace wiring. B. Replace display board. C. Replace control board. D. Check electricity.
<b>3. E1 Flash</b>	A. Wiring of locating board with controller damaged. B. Locating board damaged. C. Mechanical driven damaged. D. Control board damaged. E. Wiring of motor with controller damaged. F. Motor damaged.	A. Replace wiring. B. Replace locating board. C. Check and repair mechanical part. D. Replace control board. E. Replace wiring. F. Replace motor.
<b>4. E2 Flash</b>	A. Hall component on locating board damaged. B. Wiring of locating board with controller damaged. C. Control board damaged.	A. Replace locating board. B. Replace wiring. C. Replace control board.
<b>5. E3 or E4 Flash</b>	A. Control board damaged.	A. Replace control board.

### 3.7. Assembly & Parts

#### F71B3 (53602) Valve Body Assembly

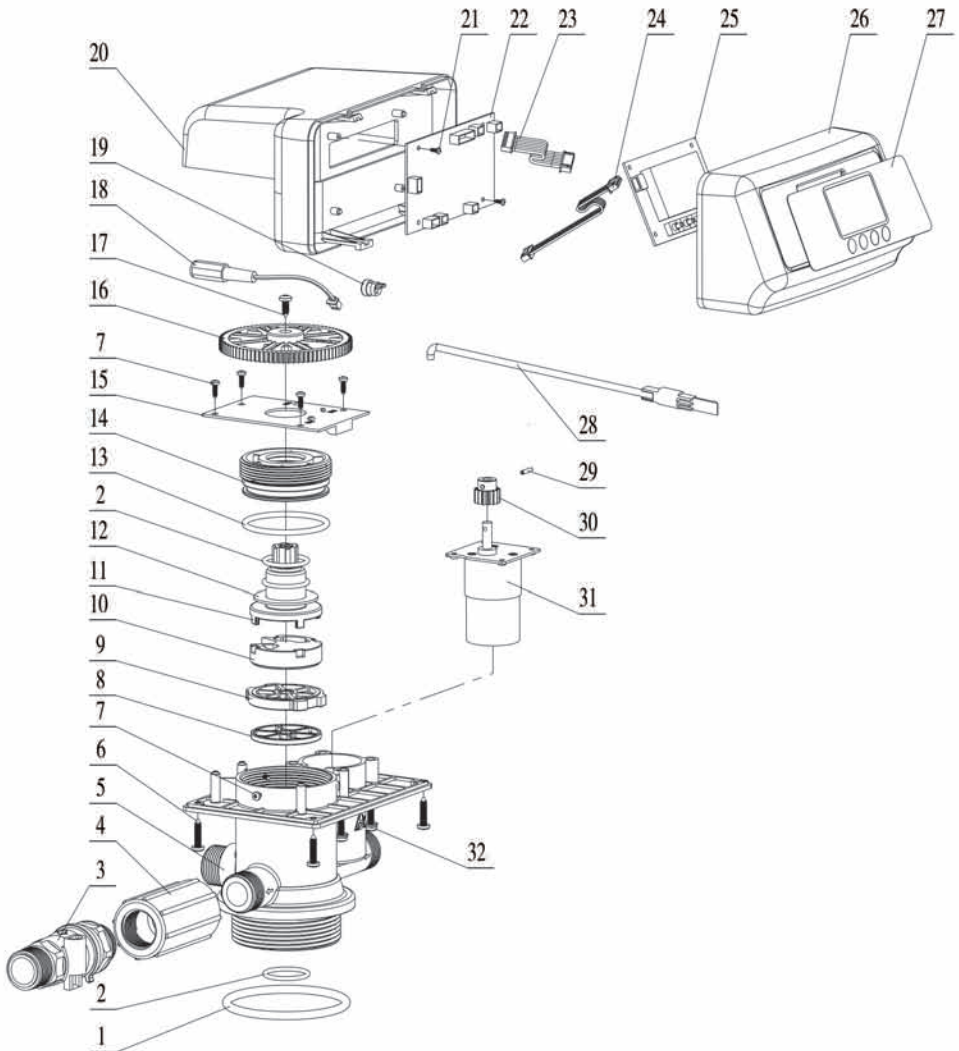



**F71B3 (53602) Valve Body Components**

<b>Item No.</b>	<b>Description</b>	<b>Part No.</b>	<b>Quantity</b>	<b>Item No.</b>	<b>Description</b>	<b>Part No.</b>	<b>Quantity</b>
1	O-ring 73x5.3	8378143	1	17	Screw, Cross ST3.9X13	8909013	1
2	O-ring 25.8x2.65	8378078	1	18	Wire for Power	5513001	1
3	Flow Meter	5447002	1	19	Cable Clip	8126004	2
4	Joint	8458206	1	20	Dust Cover	8005005	1
5	Valve Body (ABS+GF10)	8022048	1	21	Screw, Cross ST2.2X6.5	8909004	2
	Valve Body (PPO+GF20)	8022049		22	Control Board	6382098	1
6	Screw, Cross ST3.9X16	8909016	4	23	Wire for Locating Board	5511001	1
7	Screw, Cross ST2.9X9.5	8909008	7	24	Wire for Display Board	5512001	1
8	Sealing Ring	8370038	1	25	Display Board	6381003	1
9	Fixed Disk	8469018	1	26	Front Cover	8300004	1
10	Moving Disk	8459019	1	27	Label	8865004	1
11	Shaft	8258009	1	28	Probe Wire	6386001	1
12	Anti-friction Washer	8216010	1	29	Pin $\Phi$ 2.5X12	8993003	1
13	O-ring 50.39x3.53	8378107	1	30	Small Gear, Motor	8241010	1
14	Fitting Nut	8092007	1	31	Motor	6158006	1
15	Locating Board	6380009	1	32	Screw, Cross M4x25	8902008	4
16	Big Gear	5241005	1				

MODEL: F71B3/F67C3/F67B3/F67B3-A/N75A3/N75B3

F67B3 (53604S) Valve Body Assembly

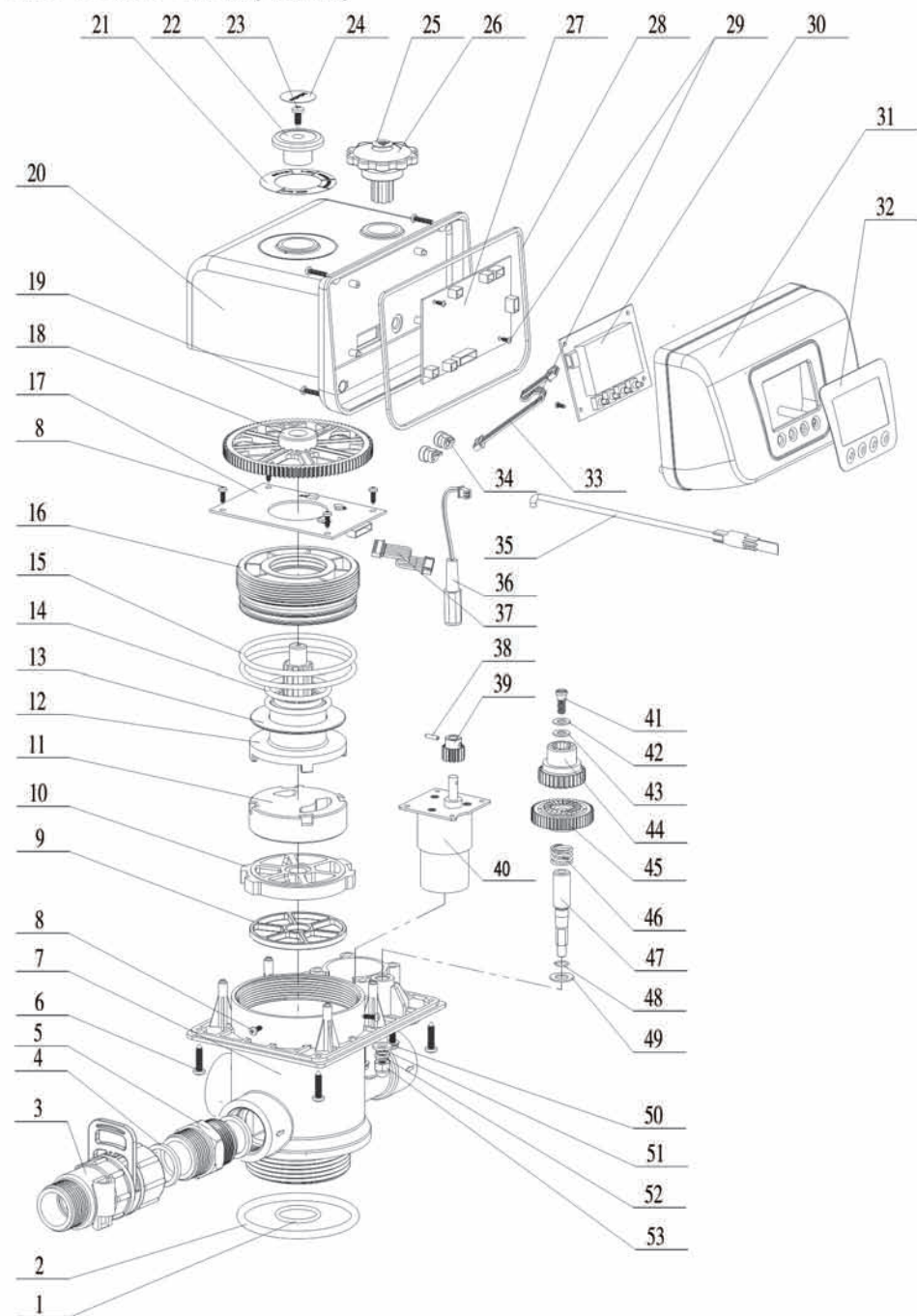

**F67B3 (53604S) Valve Body Components**

Item No.	Description	Part No.	Quantity	Item No.	Description	Part No.	Quantity
1	O-ring 73x5.3	8378078	1	27	Control Board	6382098	1
2	O-ring 25.8x2.65	8378143	1	28	Sealing Ring	8371003	1
3	Flow Meter	5447007	1	29	Screw, Cross	8909004	4
4	Sealing Ring	8371001	1	30	Display Board	6386003	1
5	Joint	8458205	1	31	Control Board	8300001	1
6	Screw, Cross ST3.9X16	8909016	4	32	Label	8865002	1
7	Valve Body (ABS+GF10)	8022037	1	33	Wire for Display Board	5512001	1
	Valve Body (PPO+GF20)	8022038		34	Cable Clip	8126004	2
8	Screw, Cross ST2.9X9.5	8909008	7	35	Probe Wire	6386001	1
9	Sealing Ring	8370027	1	36	Wire for Power	5513001	1
10	Fixed Disk	8469013	1	37	Wire for Locating Board	5511001	1
11	Moving Disk	8459014	1	38	Pin	8993001	1
12	Shaft	8258001	1	39	Small Gear, Motor	8241004	1
13	Anti-friction Washer	8216004	1	40	Motor	6158016	1
14	O-ring	8378184	2	41	Bolt	8906001	1
15	O-ring	8378128	2	42	Washer	8950004	1
16	Fitting Nut	8092004	1	43	Anti-friction Washer	8216005	1
17	Locating Board	6380004	1	44	Driven Gear	8243001	1
18	Big Gear	5241001	1	45	Variable Gear	8243002	1
19	Screw, Cross	8909010	4	46	Spring	8282001	1
20	Dust Cover	8005001	1	47	Connecting Rod	8040001	1
21	Label	8869001	1	48	Clip Ring	8994001	1
22	Pointer	8441001	1	49	Check Ring	8950006	1
23	Screw, Cross	8909013	1	50	Screw, Cross	8902009	4
24	Symbol Label	8868004	1	51	Washer	8952007	1
25	Label	8860001	1	52	Spring Washers	8953001	1
26	Hand Wheel	8253001	1	53	Nut M6	8949001	1

**Note:**

- For F67B3-A components, the part No.7 valve body code is 8022062.
- For F67C3 components, there is no spare parts from No.21 to No.26, and No. 41 to No.49. The No.7 valve body code is 8022039. No.18 gear code is 5241002, No.20 dust cover code is 8005006

N75A3 (53610) Valve Body Assembly

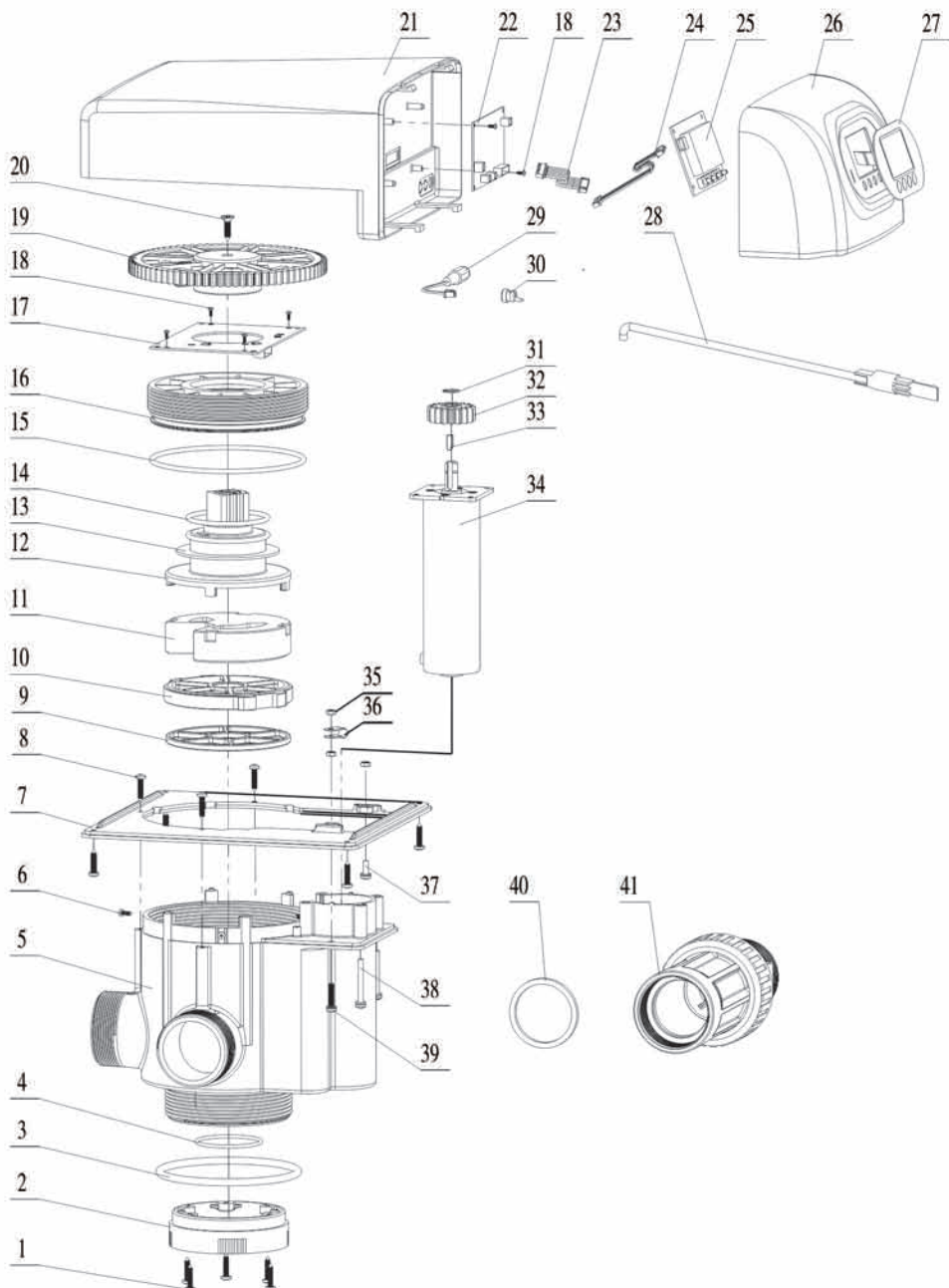

**N75A3 (53610) Valve Body Assembly**

<b>Item No.</b>	<b>Description</b>	<b>Part No.</b>	<b>Quantity</b>	<b>Item No.</b>	<b>Description</b>	<b>Part No.</b>	<b>Quantity</b>
1	Screw, Cross	8909003	5	21	Dust Cover	8005010	1
2	Connector	8458018	1	22	Control Board	6382027	1
3	O-ring	8378146	1	23	Wire for Locating Board	5511002	1
4	O-ring	8378071	1	24	Wire for Display Board	5512001	1
5	Valve Body (ABS+GF10)	8022055	1	25	Display Board	6381003	1
	Valve Body (PPO+GF10)	8022056		26	Front Cover	8300017	1
6	Screw, Cross	8909008	3	27	Label	8865016	1
7	Connecting Plate	8152007	1	28	Probe Wire	6386001	1
8	Screw, Cross	8909016	7	29	Wire Power	5513001	1
9	Sealing Ring	8370014	1	30	Cable Clip	8126004	2
10	Fixed Disk	8469009	1	31	Clip	8994009	1
11	Moving Disk	8459022	1	32	Small Gear, Motor	8241008	1
12	Shaft	8258005	1	33	Pin	8971001	1
13	Anti-friction Washer	8216006	1	34	Motor	6158037	1
14	O-ring	8378110	2	35	Hexagon Nut	8940002	3
15	O-ring	8378133	1	36	Clip	8126002	1
16	Fitting Nut	8092005	1	37	Screw, Cross	8902005	1
17	Locating Board	6380016	1	38	Screw, Cross	8902012	4
18	Screw, Cross	8909004	6	39	Screw, Cross	8902007	1
19	Big Gear	5241014	1	40	Sealing Ring	8371008	1
20	Screw, Cross	8909018	1	41	Flow Meter	5447003	1

N75B3 (53610B) Valve Body Assembly

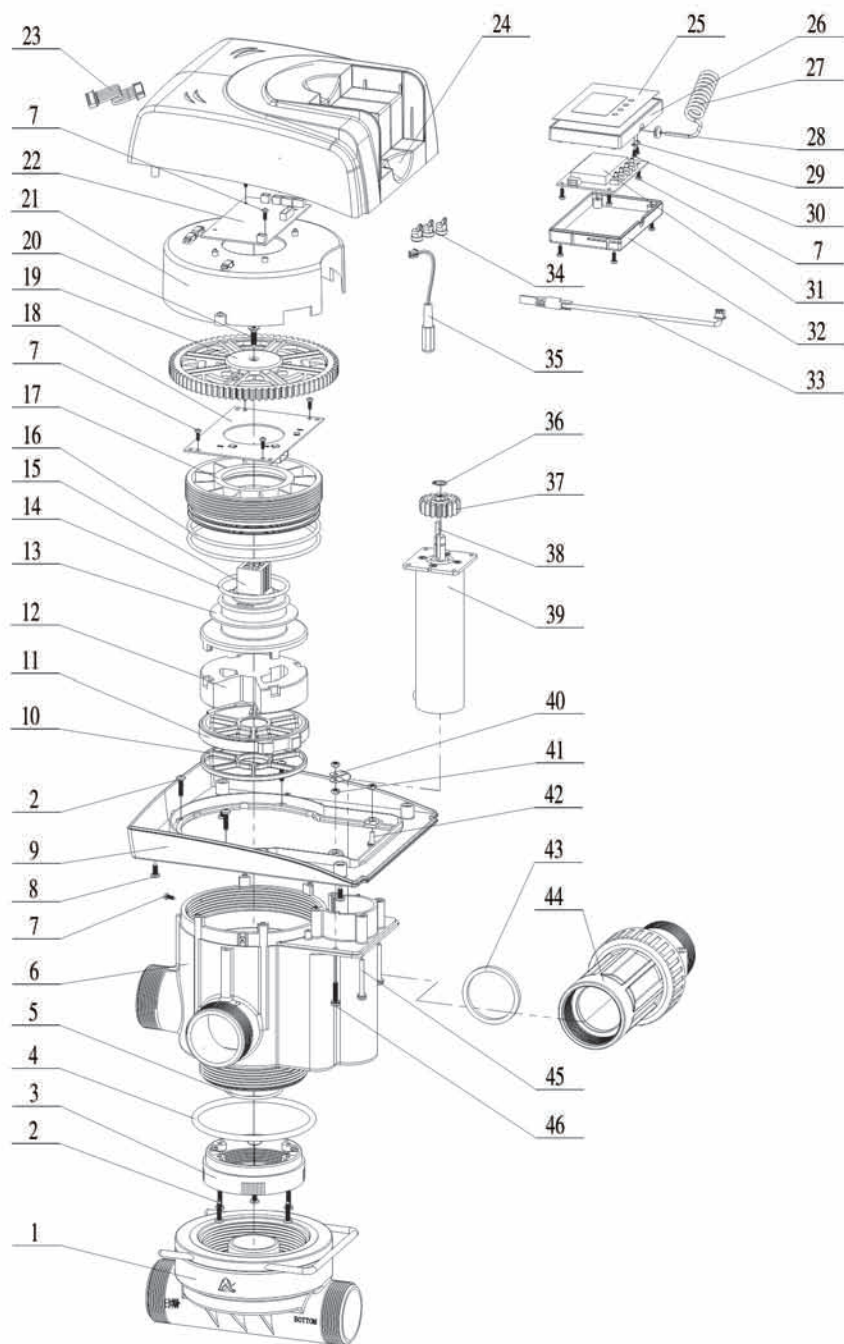

**N75B3 (53610B) Valve Body Assembly**

<b>Item No.</b>	<b>Description</b>	<b>Part No.</b>	<b>Quantity</b>	<b>Item No.</b>	<b>Description</b>	<b>Part No.</b>	<b>Quantity</b>
1	Side-mounted Connector	5458002	1	24	Dust Cover	8005023	1
2	Screw, Cross	8909003	8	25	Label	8865023	1
3	Connector	8458018	1	26	Front Cover	8300025	1
4	O-ring	8378146		27	Three Core Spring Wire	5517003	11
5	O-ring	8378071	1	28	Bushing	8126006	1
6	Valve Body (ABS+GF10)	8022055	1	29	Clip	8126001	1
	Valve Body (PPO+GF10)	8022056		30	Screw, Cross	8909004	2
7	Screw, Cross	8909008	19	31	Display Board	6381003	1
8	Screw, Cross	8909013	4	32	Cover	8315016	1
9	Connecting Plate	8152012	1	33	Probe Wire	6386001	1
10	Sealing Ring	8370014	1	34	Buckle	8126004	3
11	Fixed Disk	8469009	1	35	Wire for Power	5513001	1
12	Moving Disk	8459022	1	36	Pin	8994009	1
13	Anti-friction Washer	8216006	1	37	Small Gear, Motor	8241008	1
14	O-Ring	8378110	2	38	Bolt	8971001	1
15	Shaft	8258005	1	39	Motor	6158037	1
16	O-ring	8378133	2	40	Buckle	8126002	1
17	Fitting Nut	8092032	1	41	Hexagonal Nut	8940002	1
18	Locating Board	6380016	1	42	Screw, Cross	8902005	3
19	Big Gear	5241014	1	43	Sealing Ring	8371008	1
20	Screw, Cross	8909018	1	44	Flow Meter	5447003	1
21	Fixed Base	8109004	1	45	Screw, Cross	8902012	4
22	Control Board	6382098	1	46	Screw, Cross	8902007	1
23	Wire for Locating Board	5511002	1				

5458002 Side-mounted Connector

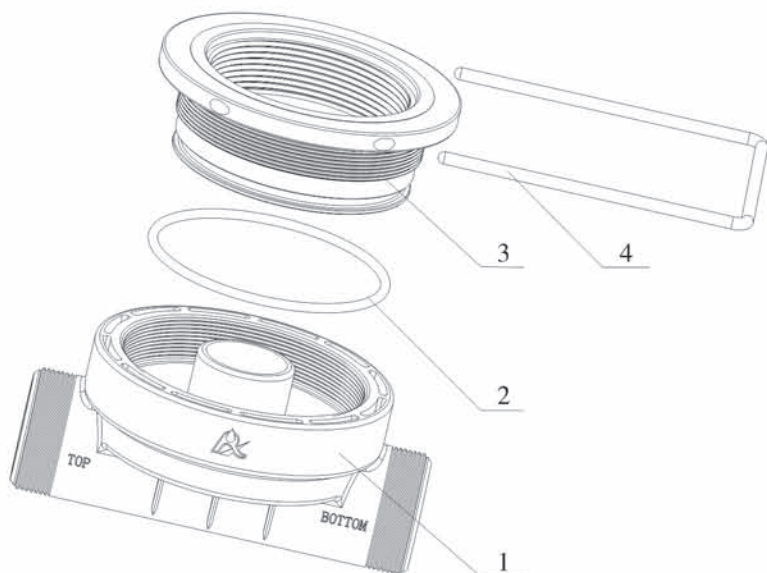

5458002 Side-mounted Connector Part Number

Item No.	Description	Part No.	Quantity	Item No.	Description	Part No.	Quantity
1	Adaptor	8458037	1	3	Connector	8457017	1
2	O-ring 110x4.5	8378140	1	4	Steel Fork	8271003	1

5447002 Flow Meter Structure

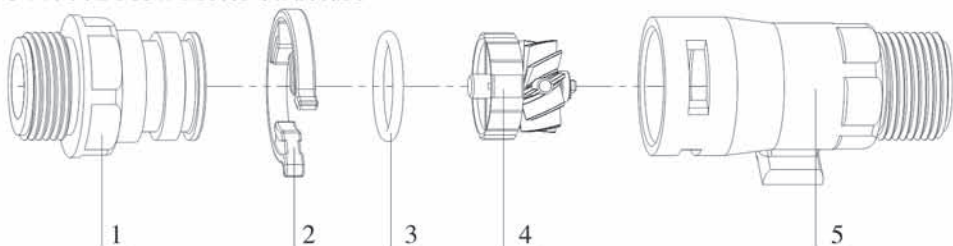

5457002 Flow Meter Part Number:

Item No.	Description	Part No.	Quantity	Item No.	Description	Part No.	Quantity
1	Connector	8458014	1	4	Impeller	5295002	1
2	Clip	8270005	1	5	Shell	8002006	1
3	O-rings	8378064	1				



5447007 Flow Meter

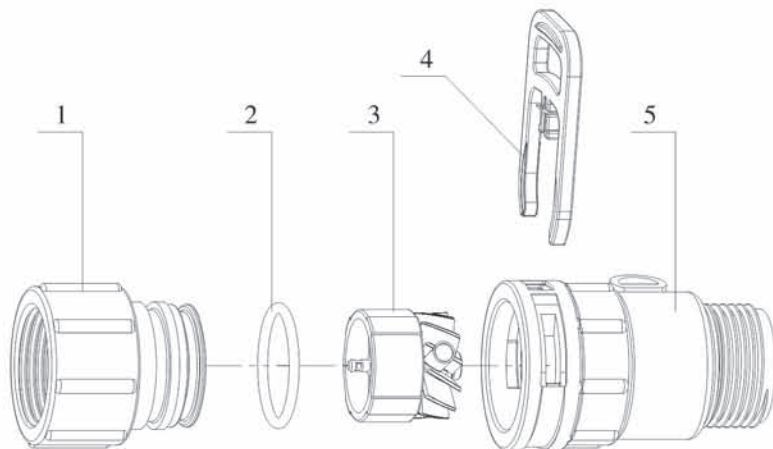

5457007 Flow Meter Part Number

Item No.	Description	Part No.	Quantity	Item No.	Description	Part No.	Quantity
1	Animated Nut	8945001	1	4	Clip	8270004	1
2	O-ring	8378081	1	5	Shell	8002001	1
3	Impeller	5295003	1				

5447003 Flow Meter

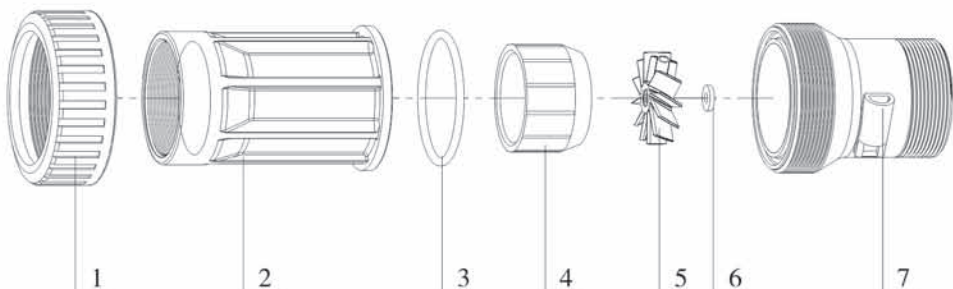

5457003 Flow Meter Part Number

Item No.	Description	Part No.	Quantity	Item No.	Description	Part No.	Quantity
1	Animated Nut	8947004	1	5	Impeller	5436005	1
2	Connector	8458016	1	6	Bush	8210002	1
3	O-ring	8378081	1	7	Shell	5002002	1
4	Toggle	8109006	1				

## 4. Warranty Card

### Dear client:

This warranty card is the guarantee proof of RUNXIN brand multi-functional flow control valve. It is kept by client self. You could get the after-sales services from the supplier which is appointed by RUNXIN manufacturer. Please keep it properly. It couldn't be retrieved if lost. It couldn't be repaired free of charge under the below conditions:

1. Guarantee period expired. (One year)
2. Damage resulting from using, maintenance, and keeping that are not in accordance with the instruction.
3. Damage resulting from repairing not by the appointed maintenance personnel.
4. Content in guarantee proof is unconfirmed with the label on the real good or be altered.
5. Damage resulting from force majeure.

<b>Product Name</b>	<b>Multi-functional Flow Control Valve for Water Treatment Systems</b>			
<b>Model</b>		<b>Code of Valve Body</b>		
<b>Purchase Company Name</b>		<b>Tel/Cel.</b>		
<b>Problem</b>				
<b>Solution</b>				
<b>Date of Repairing</b>		<b>Date of Examination</b>		<b>Maintenance Man Signature</b>

When product need warranty service, please fill in the below content and sent this card together with the product to the appointed suppliers or Runxin company.

<b>End-user Company Name</b>		<b>Tel/Cel.</b>	
<b>Purchase Company Name</b>		<b>Tel/Cel.</b>	
<b>Model</b>		<b>Code of Valve Body</b>	
<b>Tank Size <math>\phi \times</math></b>	<b>Filter Material</b>	<b>Kg</b>	<b>Water Source:</b> Ground-water <input type="checkbox"/> Tap Water <input type="checkbox"/>
<b>Service Time <math>m^3</math></b>	<b>Backwash Time</b>	<b>min</b>	<b>Fast Rinse Time</b> <b>min</b>
<b>Problem Description</b>			



---

**WENZHOU RUNXIN MANUFACTURING MACHINE CO., LTD**

**ADD: Jinger Road, Shatou Group, Linjiang, Lucheng District, Wenzhou, Zhejiang, China**

**Tel: +86-577-88635628 88630038 Fax: +86-0577-88633258**

**Http://www.run-xin.com Email:sales@run-xin.com**